

HYBEKO SHORE POWER MACHINE

Electrical schematic

Model: SP S-45XC

S.nr: SP45E-3001

HYBEKO

The logo for HYBEKO, featuring the brand name in a bold, red, sans-serif font. A thick blue horizontal bar is positioned directly beneath the text.

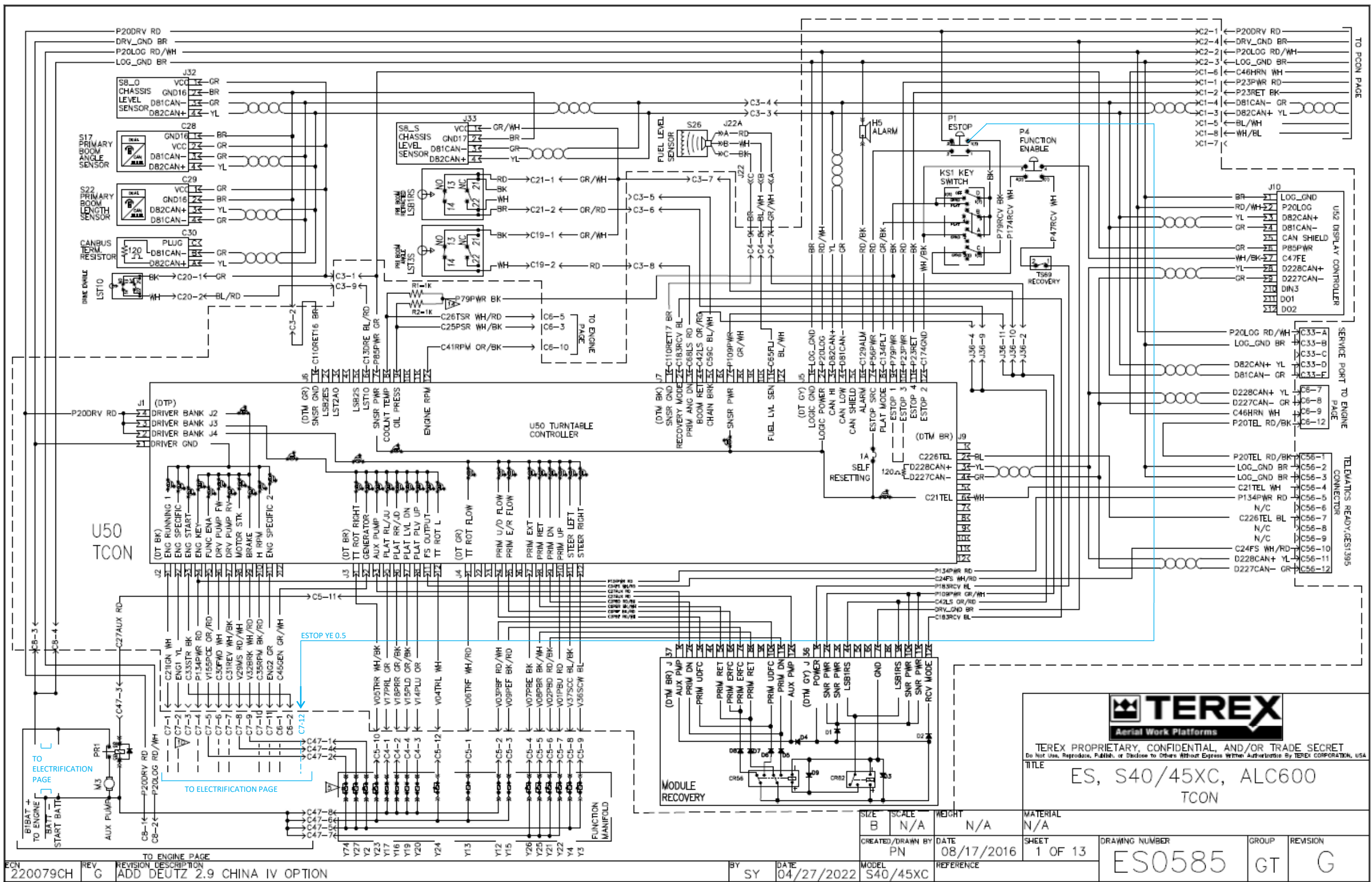

TEREX
Aerial Work Platforms

TEREX PROPRIETARY, CONFIDENTIAL, AND/OR TRADE SECRET
Do Not Use, Reproduce, Publish, or Disclose to Others Without Express Written Authorization By TEREX CORPORATION, USA

TITLE
ES, S40/45XC, ALC600
TCON

ECN	220079CH	REV	G	REVISION DESCRIPTION	ADD DEUTZ 2.9 CHINA IV OPTION
-----	----------	-----	---	----------------------	-------------------------------

BY	SY	DATE	04/27/2022	MODEL	S40/45XC	REFERENCE	
SIZE	B	SCALE	N/A	WEIGHT	N/A	MATERIAL	N/A
CREATED/DRAWN BY	PN	DATE	08/17/2016	SHEET	1 OF 13	DRAWING NUMBER	ES0585
GROUP	GT	REVISION	G				

TITLE Hybeko S-45XC V2 Electric – TCON PAGE		
MODEL HYBEKO S-45XC V2 ELECTRIC	DRAWING NO D20240308-001A	PAGE 1/8
CREATED BY / DATE MHE 8.3.2024	REVISED BY / DATE	REVISION DESCRIPTION Document created

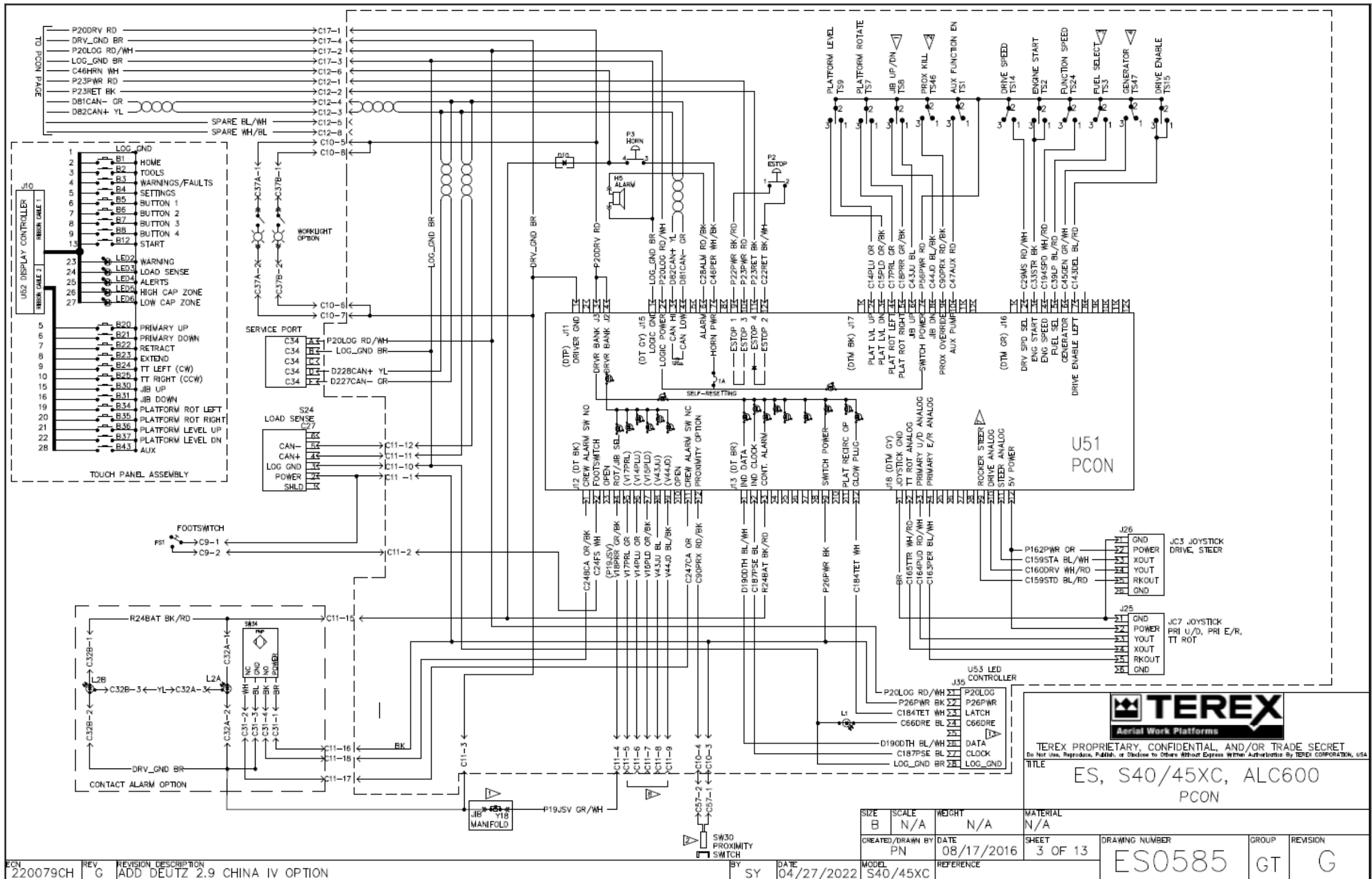

TEREX PROPRIETARY, CONFIDENTIAL, AND/OR TRADE SECRET
Do Not Use, Reproduce, Publish, or Disclose to Others Without Express Written Authorization by TEREX CORPORATION, USA

TITLE
ES, S40/45XC, ALC600
PCON

SIZE B	SCALE N/A	WEIGHT N/A	MATERIAL N/A
CREATED/DRAWN BY PN	DATE 08/17/2016	SHEET 3 OF 13	DRAWING NUMBER ES0585
GROUP GT	REVISION G		

ECN	REV	REVISION DESCRIPTION
220079CH	G	ADD DEUTZ 2.9 CHINA IV OPTION

TITLE Hybeko S-45XC V2 Electric – PCON PAGE			
MODEL HYBEKO S-45XC V2 ELECTRIC	DRAWING NO D20240308-001A	PAGE 2/8	
CREATED BY / DATE MHE 8.3.2024	REVISED BY / DATE	REVISION DESCRIPTION Document created	

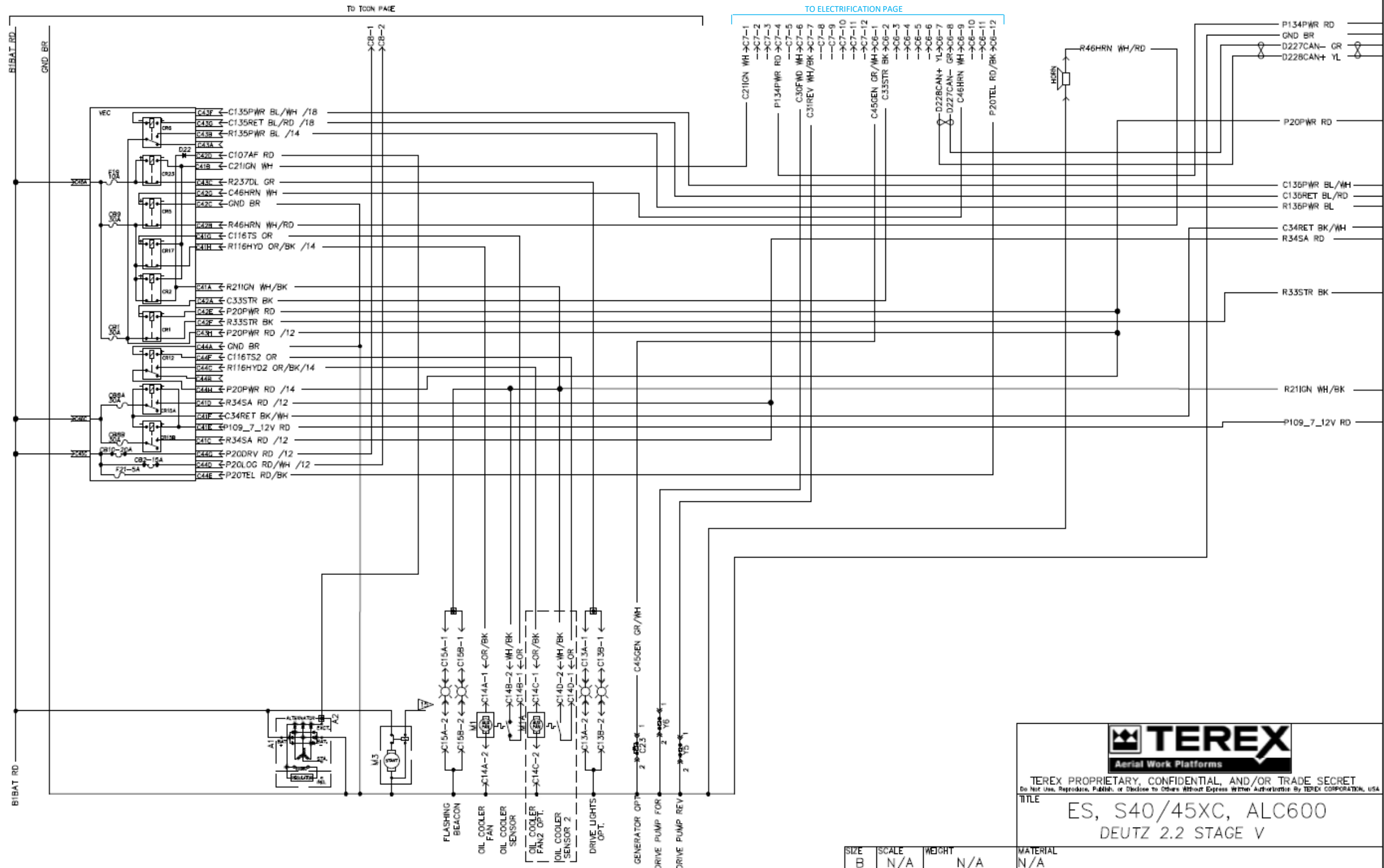

TEREX PROPRIETARY, CONFIDENTIAL, AND/OR TRADE SECRET
Do Not Use, Reproduce, Publish, or Disclose to Others Without Express Written Authorization by TEREX CORPORATION, USA

TITLE
ES, S40/45XC, ALC600
DEUTZ 2.2 STAGE V

SIZE B	SCALE N/A	WEIGHT N/A	MATERIAL N/A
CREATED/DRAWN BY PN	DATE 08/17/2016	SHEET 6 OF 13	DRAWING NUMBER ES0585
GROUP GT	REVISION G		

ECN	REV	REVISION DESCRIPTION
220079CH	G	ADD DEUTZ 2.9 CHINA IV OPTION

BY SY DATE 04/27/2022 MODEL S40/45XC REFERENCE

TITLE Hybeko S-45XC V2 Electric – ENGINE PAGE 1/2		
MODEL HYBEKO S-45XC V2 ELECTRIC	DRAWING NO D20240308-001A	PAGE 3/8
CREATED BY / DATE MHE 8.3.2024	REVISED BY / DATE	REVISION DESCRIPTION Document created

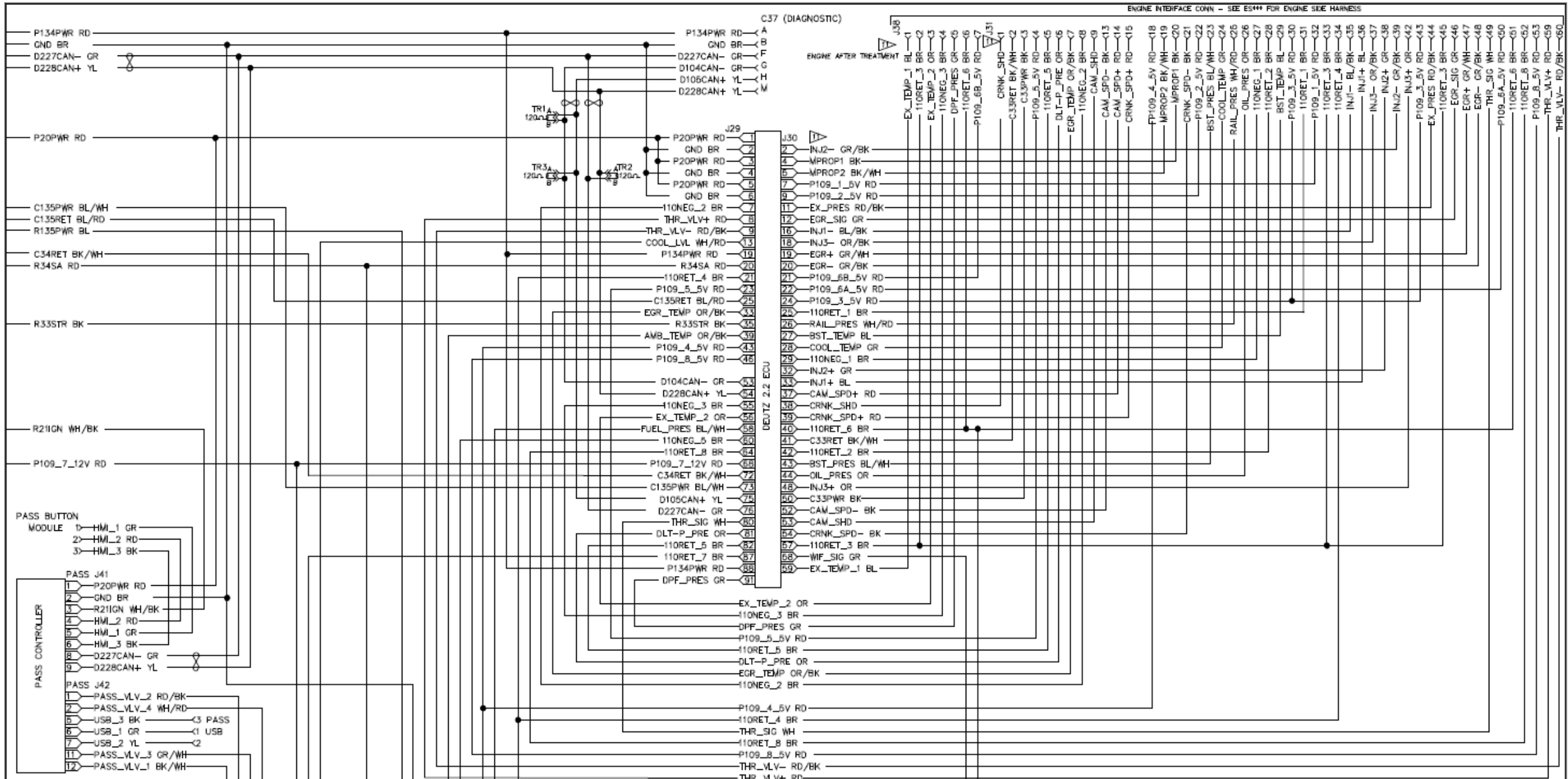

TEREX PROPRIETARY, CONFIDENTIAL, AND/OR TRADE SECRET
Do Not Use, Reproduce, Publish, or Disclose to Others Without Express Written Authorization by TEREX CORPORATION, USA

TITLE
ES, S40/45XC, ALC600
DEUTZ 2.2 STAGE V

SIZE B	SCALE N/A	WEIGHT N/A	MATERIAL N/A
CREATED/DRAWN BY PN	DATE 08/17/2016	SHEET 7 OF 13	DRAWING NUMBER ES0585
BY SY	DATE 04/27/2022	MODEL S40/45XC	GROUP GT
REVISION G		REVISION G	

ECN 220079CH REV G REVISION DESCRIPTION ADD DEUTZ 2.9 CHINA IV OPTION

TITLE Hybeko S-45XC V2 Electric – ENGINE PAGE 2/2			
MODEL HYBEKO S-45XC V2 ELECTRIC	DRAWING NO D20240308-001A	PAGE 4/8	
CREATED BY / DATE MHE 8.3.2023	REVISED BY / DATE	REVISION DESCRIPTION Document created	

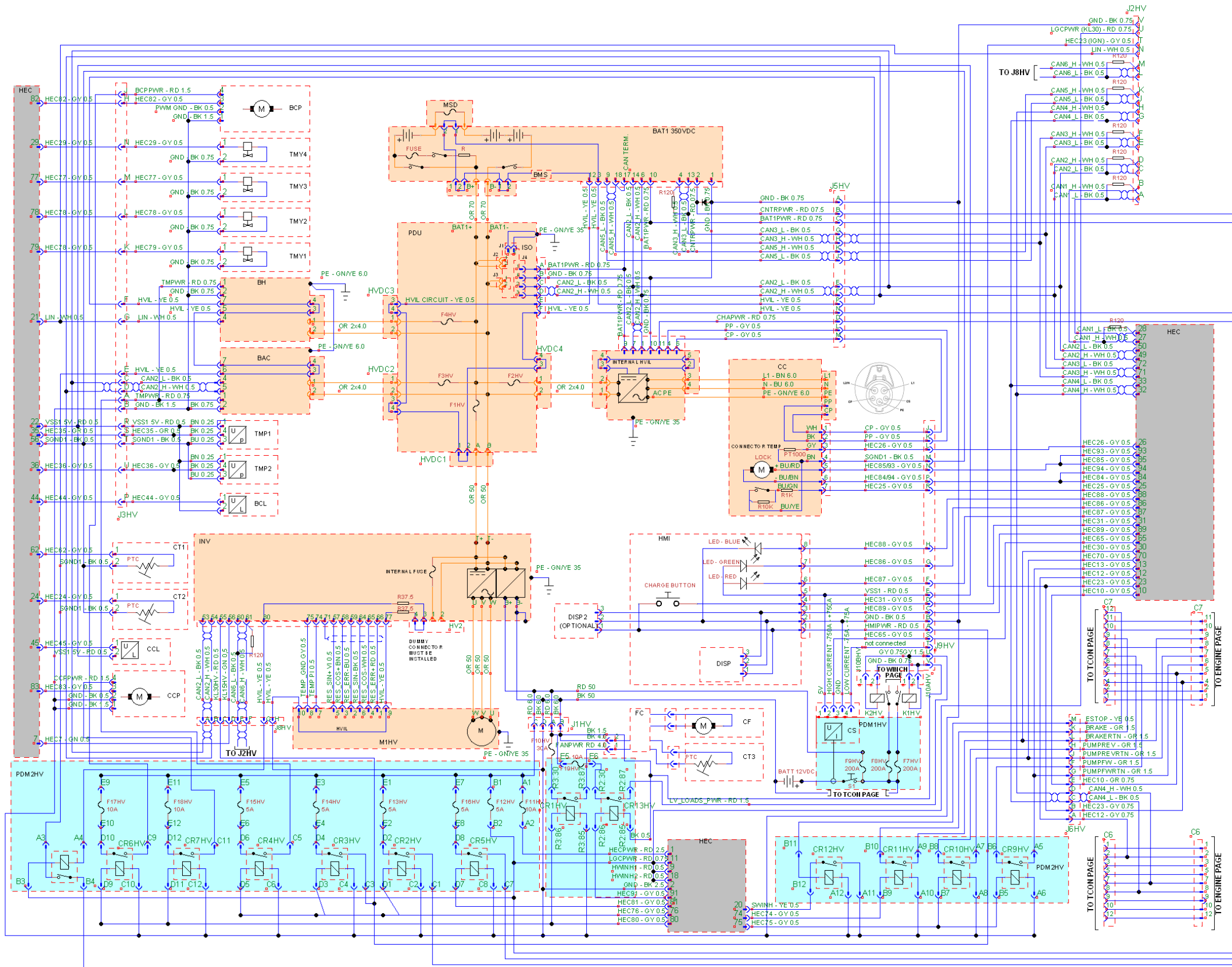

HYBRiA PROPRIETARY, CONFIDENTIAL AN/OR TRADE SECRET

Do not Use, Reproduce, Publish or Disclose to Others Without Express Authorization By Hybria Ltd, Finland.

TITLE Hybeko S-45XC V2 Electric – ELECTRIFICATION PAGE			
MODEL HYBEKO S-45XC V2 ELECTRIC	DRAWING NO D20240308-001A	PAGE 5/8	
CREATED BY / DATE MHE 8.3.2024	REVISED BY / DATE	REVISION DESCRIPTION Document created	

LED BOARD

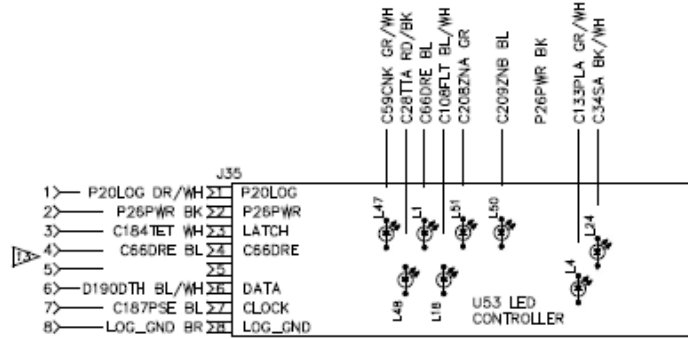

KS CONTACT DETAIL

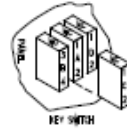

CONTACT	GROUND/PLATFORM HEIGHTER TRIP-TABLE				
	KEYSWITCH POSITION				
	OFF	GROUND	PLATFORM		
A (NC)	HELD OPEN	CLOSED	HELD OPEN		POWER TO GROUND BUS
B (NO)	OPEN	OPEN	HELD CLOSED		POWER TO PLATFORM
C (NC)	HELD OPEN	CLOSED	HELD OPEN		POWER TO RECOVERY SH
D (NC)	HELD OPEN	CLOSED	CLOSED		POWER TO PLATFORM STOP

GENIE MACHINE FUNCTIONS RELAY

- CR1 ENGINE START RELAY
- CR2 ENGINE RUN RELAY
- CR3 LOW RPM RELAY
- CR4 HIGH RPM RELAY
- CR5 HORN RELAY
- CR6 FUEL PUMP RELAY
- CR7 LPG SOLENOID RELAY
- CR15A GLOW PLUG RELAY A
- CR15B GLOW PLUG RELAY B
- CR23 DRIVE LIGHT RELAY
- CR39 AUXILIARY SHUT DOWN RELAY
- CB1 ENGINE CONTROL POWER
- CB2 SYSTEM CONTROL LOGIC POWER
- CB8 GLOW PLUG CB
- CB9 ENGINE RUN/OPTIONS/ACCESSORIES
- CB10 SYSTEM CONTROL DRIVER POWER
- F19 DRIVE LIGHT CB
- F21 TELEMATIC OPTION FUSE
- D1 ALTERNATOR FIELD DIODE

CONNECTORS DESC.

- | | | |
|---|----------------------|--|
| CONNECTORS | CONNECTORS | JACKS |
| C1 BOOM CABLE (BASE) - CONTROLS | C60 | J1 TCON POWER |
| C2 BOOM CABLE (BASE) - POWER | C61 VEC2-BLACK-8 PIN | J2 TCON ENGINE |
| C3 BOOM SENSORS | C62 VEC2-BLACK-8 PIN | J3 TCON FUNCTIONS |
| C4 FUNCTION MANIFOLD | C63 VEC2-BLUE-8 PIN | J4 TCON FUNCTIONS |
| C5 FUNCTION MANIFOLD | C64 VEC2-GREEN-8 PIN | J5 TCON LOGIC |
| C6 ENGINE | C65 VEC2-GRAY-2 PIN | J6 TCON LIMIT SWITCHES |
| C7 ENGINE | C66 VEC2-BLACK-2 PIN | J7 TCON LIMIT SWITCHES |
| C8 ENGINE - POWER | C72 ECU | J8 TCON UNUSED |
| C9 FOOTSWITCH | | J9 TCON COMMUNICATION |
| C10 PLATFORM OPTIONS | | J10 DISCON |
| C11 PLATFORM MANIFOLD | | J11 PCON POWER |
| C12 BOOM CABLE (PLATFORM) - CONTROLS | | J12 PCON FUNCTIONS |
| C13 DRIVE LIGHTS | | J13 PCON FUNCTIONS |
| C14 HYD OIL COOLER | | J14 PCON UNUSED |
| C15 FLASHING BEACONS | | J15 PCON LOGIC |
| C16 ENGINE DIAGNOSTIC PORT | | J16 PCON TOGGLES |
| C17 BOOM CABLE (PLATFORM) - POWER | | J17 PCON TOGGLES |
| C18 D2.9 ENGINE CONNECTOR | | J18 PCON JOYSTICKS |
| C19 LST3S | | J19 PCON UNUSED |
| C20 LST10 | | J20 BOOM ANGLE SENSOR OPERATIONAL - NOT USED |
| C21 LSB1RS | | J21 BOOM ANGLE SENSOR SAFETY - NOT USED |
| C22 LSB2S | | J22 FUEL LEVEL SENSOR |
| C23 GEN FROM ENG HARN | | J23 PLATFORM LEVEL SENSOR OPERATIONAL - NOT USED |
| C24 WELDER ENCLOSURE | | J24 PLATFORM LEVEL SENSOR SAFETY - NOT USED |
| C25 GM3.0 VEHICLE INTERFACE CONNECTOR 1 | | J25 BOOM FN JOYSTICK |
| C26 GM3.0 VEHICLE INTERFACE CONNECTOR 2 | | J26 DRIVE FN JOYSTICK |
| C27 LOAD SENSE | | J27 404D ECG-BLACK |
| C28 BOOM ANGLE SENSOR | | J28 404D ECG-GRAY |
| C29 BOOM EXTENSION STRING-POT | | J29 D2.9/D2.2 ECU-1 |
| C30 CANBUS TERMINATING RESISTOR | | J30 D2.9/D2.2 ECU-2 |
| C31 CREW ALARM PROXY SWITCH | | J31 D2.9/D2.2 ENGINE INTERFACE |
| C32 CREW ALARM LIGHTS | | J32 CHASSIS TILT SENSOR OPERATIONAL |
| C33 GBOX SERVICE PORT | | J33 CHASSIS TILT SENSOR SAFETY |
| C34 PBOX SERVICE PORT | | J34 D2011 ENGINE INTERFACE |
| C35 404D SPEED SENSOR | | J35 LED PCB |
| C36 404D FUEL SOLENOID | | J36 RECOVERY MODULE POWER |
| C37 WORK LIGHTS | | J37 RECOVERY MODULE I/O |
| C38 DEUTZ D2011 ECU CONN1 | | J38 RPM SELEND |
| C39 FORD VEHICLE INTERFACE CONNECTOR 1 | | |
| C40 DEUTZ D2011 ECU CONN2 | | |
| C41 VEC-BLACK-8 PIN | | |
| C42 VEC-GRAY-8 PIN | | |
| C43 VEC-BLUE-8 PIN | | |
| C44 VEC-GREEN-8 PIN | | |
| C45 VEC-GRAY-2 PIN | | |
| C46 VEC-BLACK-2 PIN | | |
| C47 FUNCTION ENABLE | | |
| C48 BRAKE | | |
| C49 MOTOR STROKE | | |
| C50 DRIVE PUMP | | |
| C51 ENGINE ECG1 | | |
| C52 ENGINE ECG2 | | |
| C53 PLAT RECIRC VALVE | | |
| C56 TELEMATICS | | |
| C57 ACP | | |
| C58 | | |
| C59 | | |
| C60 ENGINE RUN SIGNAL FOR OIL COOLER | | |

NOTES

- ALL COMPONENTS ARE SHOWN WITH MACHINE IN THE STOWED AND OFF POSITION.
- SCHEMATIC IS BUILT ACCORDING TO GEP1460 AND GES1325.

- ▷ S45 ONLY, ENERGIZE FOR ROTATE FUNCTION
- ▷ AIRCRAFT PROTECTION ONLY
- ▷ LP/GAS ENGINE ONLY
- ▷ GENERATOR OPTION ONLY
- ▷ NO SUPPRESSION DIODE ON PROPORTIONAL VALVE COILS
- ▷ UNUSED
- ▷ STEER ROCKER OPTION
- ▷ NOT USE ON S40/45XC
- ▷ CONTACT OPTION
- ▷ ENG1: C5-2 C34SA/C27AUX/C39LP
- ▷ ENG2: C5-11 C34SA/C27AUX/C39LP

TWISTED PAIRS

- INJ1 A33 - INJ1 A16
- INJ2 A03 - INJ2 A46
- INJ3 A02 - INJ3 A32
- INJ4 A18 - INJ4 A48
- EGRSOLPWR - EGRSOLGND
- CAMSPD A52 - CAMSPD A37
- CAMSPD SHD
- CRNKSPD A39 - CRNKSPD A54
- CRNKSPD SHD

SHIELDED TWISTED PAIRS

- INJ1PWR - INJ1SIG : SHIELDED BY INJ_SHD
- INJ2PWR - INJ2SIG : SHIELDED BY INJ_SHD
- INJ3PWR - INJ3SIG : SHIELDED BY INJ_SHD
- INJ4PWR - INJ4SIG : SHIELDED BY INJ_SHD
- CAM+ - CAM- : SHIELDED BY SNSR_SHD
- CNK+ - CNK- : SHIELDED BY SNSR_SHD
- RPPWR - RPSIG1 - RPSIG2 : SHIELDED BY RP_SHD

TWISTED PAIRS

- SVC- : SVC+
- ETC- : ETC+
- EGR- : EGR+

DETAIL ON SHEET 6

- ▷ R1 AND R2 ONLY USED ON D2011L03 AND FORD MSG425 ENGINES ONLY.
- ▷ WIRING IS ON SUPPLIED ENGINE HARNESS

REFERENCE:

- HARNESS MAP: 1277933
- STANDARD VEC: 1269738
- PERKINS ENGINE, 2ND VEC: 1286594
- COMPONENT LEGEND CLASSIFICATION: GES1325

TEREX PROPRIETARY, CONFIDENTIAL, AND/OR TRADE SECRET
Do Not Use, Reproduce, Publish, or Disclose to Others Without Express Written Authorization By TEREX CORPORATION, USA

TITLE
ES, S40/45XC, ALC600
NOTES, LEGEND AND DETAILS

SIZE	SCALE	WEIGHT	MATERIAL
B	N/A	N/A	N/A
CREATED/DRAWN BY	DATE	SHEET	DRAWING NUMBER
PN	08/17/2016	12 OF 13	ES0585
GROUP	REVISION		
GT	G		

ECN	REV	REVISION DESCRIPTION	BY	DATE	MODEL	REFERENCE
220079CH	G	ADD DEUTZ 2.9 CHINA IV OPTION	SY	04/27/2022	S40/45XC	

TITLE Hybeko S-45XC V2 Electric - NOTES, LEGEND AND DETAILS		
MODEL HYBEKO S-45XC V2 ELECTRIC	DRAWING NO D20240308-001A	PAGE 6/8
CREATED BY / DATE MHE 8.3.2024	REVISED BY / DATE	REVISION DESCRIPTION Document created

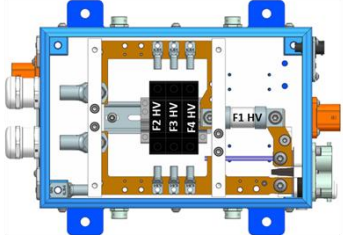
PDU	FUSE No.	FUNCTION	RATING	COMPONENT
	F1HV	Inverter	250A	Mersen MEV50A250-25G
	F2HV	Charger	25A	Mersen MEV100C25
	F3HV	HV compressor	25A	Mersen MEV100C25
	F4HV	Battery heater	25A	Mersen MEV100C25

PDM1HV	FUSE No.	FUNCTION	RATING	COMPONENT
	F7HV	Winch	200A	Mini 32Vdc bolt-down fuse
	F8HV	Winch	200A	Mini 32Vdc bolt-down fuse
	F9HV	INV - DC/DC CONVERTER OUTPUT	200A	Mini 32Vdc bolt-down fuse

PDM2HV	FUSE No.	FUNCTION	RATING	COMPONENT																																
<table border="1" data-bbox="104 721 709 953"> <tr> <td>N/A</td> <td>N/A</td> <td>F19HV 10A</td> <td>N/A</td> <td>N/A</td> <td>N/A</td> </tr> <tr> <td colspan="2">CR1HV</td> <td colspan="2">CR13HV</td> <td colspan="2">N/A</td> </tr> </table> <table border="1" data-bbox="327 1003 486 1056"> <tr> <td>F10HV – 30A</td> </tr> </table> <table border="1" data-bbox="104 1096 709 1332"> <tr> <td>F13HV 5A</td> <td>F14HV 5A</td> <td>F15HV 5A</td> <td>F16HV 5A</td> <td>F17HV 10A</td> <td>F18HV 10A</td> </tr> <tr> <td>CR2HV</td> <td>CR3HV</td> <td>CR4HV</td> <td>CR5HV</td> <td>CR6HV</td> <td>CR7HV</td> </tr> <tr> <td>F12HV 5A</td> <td rowspan="2">CR8HV</td> <td rowspan="2">CR9HV</td> <td rowspan="2">CR10HV</td> <td rowspan="2">CR11HV</td> <td rowspan="2">CR12HV</td> </tr> <tr> <td>F11HV 10A</td> </tr> </table>	N/A	N/A	F19HV 10A	N/A	N/A	N/A	CR1HV		CR13HV		N/A		F10HV – 30A	F13HV 5A	F14HV 5A	F15HV 5A	F16HV 5A	F17HV 10A	F18HV 10A	CR2HV	CR3HV	CR4HV	CR5HV	CR6HV	CR7HV	F12HV 5A	CR8HV	CR9HV	CR10HV	CR11HV	CR12HV	F11HV 10A	F10HV	CF – Cooling fan	25A	Mini 32Vdc blade fuse
	N/A	N/A	F19HV 10A	N/A	N/A	N/A																														
	CR1HV		CR13HV		N/A																															
	F10HV – 30A																																			
	F13HV 5A	F14HV 5A	F15HV 5A	F16HV 5A	F17HV 10A	F18HV 10A																														
	CR2HV	CR3HV	CR4HV	CR5HV	CR6HV	CR7HV																														
	F12HV 5A	CR8HV	CR9HV	CR10HV	CR11HV	CR12HV																														
	F11HV 10A																																			
	F11HV	HEC – Electrification control unit	10A	Mini 32Vdc blade fuse																																
	F12HV	Logic, diagnostics	5A	Mini 32Vdc blade fuse																																
	F13HV	KL30HV: HV Battery logic, PDU, Charge wake-up	5A	Mini 32Vdc blade fuse																																
	F14HV	KL30HV: Inverter, HMI	5A	Mini 32Vdc blade fuse																																
	F15HV	KL30HV: Compressor, heater	5A	Mini 32Vdc blade fuse																																
	F16HV	HV Battery contactors	10A	Mini 32Vdc blade fuse																																
	F17HV	BCP – Battery coolant pump	10A	Mini 32Vdc blade fuse																																
	F18HV	CCP – Components coolant pump	10A	Mini 32Vdc blade fuse																																
	F19HV	K1HV, K2HV – Winch supply contactors	10A	Mini 32Vdc blade fuse																																
	RELAY No.	FUNCTION	RELAY TYPE	COMPONENT																																
	CR1HV	CF – Cooling fan	ISO 7588-1 Mini relay	Song Chuan 896H-1CH-S-R1-12VDC																																
CR2HV	KL30HV: HV Battery logic, PDU, Charge wake-up	ISO 280 Ultra Micro	Song Chuan 303-1AH-C-R1 12 Vdc																																	
CR3HV	KL30HV: Inverter, HMI	ISO 280 Ultra Micro	Song Chuan 303-1AH-C-R1 12 Vdc																																	
CR4HV	KL30HV: Compressor, heater	ISO 280 Ultra Micro	Song Chuan 303-1AH-C-R1 12 Vdc																																	
CR5HV	HV Battery contactors	ISO 280 Ultra Micro	Song Chuan 303-1AH-C-R1 12 Vdc																																	
CR6HV	BCP – Battery coolant pump	ISO 280 Ultra Micro	Song Chuan 303-1AH-C-R1 12 Vdc																																	
CR7HV	CCP – Components coolant pump	ISO 280 Ultra Micro	Song Chuan 303-1AH-C-R1 12 Vdc																																	
CR8HV	INV/Motor HVIL circuit	ISO 280 Ultra Micro	Song Chuan 303-1AH-C-R1 12 Vdc																																	
CR9HV	FW Drive enable	ISO 280 Ultra Micro	Song Chuan 303-1AH-C-R1 12 Vdc																																	
CR10HV	REV Drive enable	ISO 280 Ultra Micro	Song Chuan 303-1AH-C-R1 12 Vdc																																	
CR11HV	Brakes enable	ISO 280 Ultra Micro	Song Chuan 303-1AH-C-R1 12 Vdc																																	
CR12HV	SW inhibit	ISO 280 Ultra Micro	Song Chuan 303-1AH-C-R1 12 Vdc																																	
CR13HV	K1HV, K2HV – Winch supply contactors	ISO 7588-1 Mini relay	Song Chuan 896H-1CH-S-R1-12VDC																																	

ID.	FUNCTION
BAT1	High voltage primary battery
BAC	Battery A/C compressor
BCP	Battery coolant pump
BH	Battery heater
CC	Charge connector
CCP	Components coolant pump
CF	Cooling fan
CHA	Charger
CS	Current sensor
CT1	Components coolant temperature – cold side
CT2	Components coolant temperature – hot side
DISP	Battery State of charge display
FC	Cooling fan controller
HEC	Electrification control unit
HMI	User interface assembly
HVIL	High voltage interlock
INV	Inverter
ISO	Isolation monitoring unit
MSD	Manual Service Disconnect
K1HV, K2HV	Winch contactors
M1HV	Motor
PDM1HV	12Vdc Power Distribution Unit 1 for HV system
PDM2HV	12Vdc Power Distribution Unit 2 for HV system
PDU	Power Distribution Unit – high voltage
TM	Thermo module
Y1	Thermo module change over valve
Y2	Thermo module 2-way valve
Y3	Thermo module 2-way valve
Y4	Coolant valve



HYBRiA PROPRIETARY, CONFIDENTIAL AN/OR TRADE SECRET

Do not Use, Reproduce, Publish or Disclose to Others Without Express Authorization By Hybria Ltd, Finland.

TITLE Hybeko S-45XC V2 Electric – FUSES, RELAYS AND NOTES		
MODEL HYBEKO S-45XC V2 ELECTRIC	DRAWING NO D20240308-001A	PAGE 7/8
CREATED BY / DATE MHE 8.3.2024	REVISED BY / DATE	REVISION DESCRIPTION Document created

ANSI Symbol	ANSI Code	IEC 61346-2 Symbol	IEC Code	Description
	CON		KM	Contactor contact open
	CON		KM	Contactor contact closed
	CR		KA	Relay contact open
	CR		KA	Relay contact closed
	TR		KT	Timed contact, N.O. – on delay (TDE)
	TR		KT	Timed contact, N.C. – on delay (TDE)
	TR		KT	Timed contact, N.C.– off delay (TDD)
	TR		KT	Timed contact, N.O. – off delay (TDD)
	SS		SA	Selector switch
	PB		SB	Pushbutton N.O.
	PB		SB	Pushbutton N.C.
	PB		SB	Pushbutton mushroom head
	FL		SL	Liquid level switch
	FLS		SF	Flow switch
	PS		SP	Pressure switch
	TS		ST	Temperature switch
	LS		SQ	Limit switch
	PRS		SQ	Proximity switch
	LT		HL	Indicating light
	CR		KA	Control relay coil
	CON		KM	Contactor coil
	M		KM	Motor starter coil
	TR		KA	Timer coil
	SOL		YV	Solenoid coil
	CTR		EC	Electromechanical counter
	CB		QF	Circuit breaker
	T1		X1	Terminals (reference)
			XT	Fused terminals (reference)
	FU		FU	Fuse, protective



HYBRiA PROPRIETARY, CONFIDENTIAL AN/OR TRADE SECRET

Do not Use, Reproduce, Publish or Disclose to Others Without Express Authorization By Hybria Ltd, Finland.

TITLE Hybeko S-45XC V2 Electric – SYMBOLS		
MODEL HYBEKO S-45XC V2 ELECTRIC	DRAWING NO D20240308-001A	PAGE 8/8
CREATED BY / DATE MHE 8.3.2024	REVISED BY / DATE	REVISION DESCRIPTION Document created

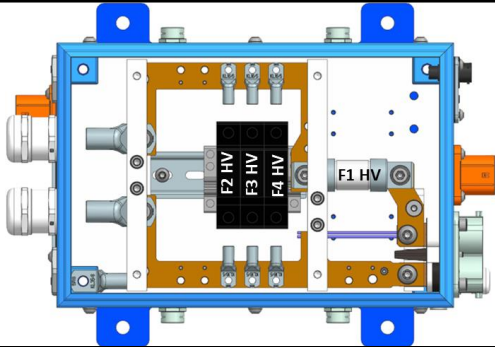
PDU	FUSE No.	FUNCTION	RATING	COMPONENT
	F1HV	Inverter	250A	Mersen MEV50A250-25G
	F2HV	Charger	25A	Mersen MEV100C25
	F3HV	HV compressor	25A	Mersen MEV100C25
	F4HV	Battery heater	25A	Mersen MEV100C25

PDM1HV	FUSE No.	FUNCTION	RATING	COMPONENT
	F7HV	Winch	100A	Mini 32Vdc bolt-down fuse
	F8HV	Winch	100A	Mini 32Vdc bolt-down fuse
	F9HV	INV - DC/DC CONVERTER OUTPUT	200A	Mini 32Vdc bolt-down fuse

PDM2HV						FUSE No.	FUNCTION	RATING	COMPONENT																											
<table border="1" data-bbox="182 937 1061 1272"> <tr> <td>N/A</td> <td>N/A</td> <td>F19HV 10A</td> <td>N/A</td> <td>N/A</td> <td>N/A</td> </tr> <tr> <td colspan="2">CR1HV</td> <td colspan="2">CR13HV</td> <td colspan="2">N/A</td> </tr> </table> <table border="1" data-bbox="505 1346 736 1427"> <tr> <td>F10HV – 30A</td> </tr> </table> <table border="1" data-bbox="182 1483 1061 1830"> <tr> <td>F13HV 5A</td> <td>F14HV 5A</td> <td>F15HV 5A</td> <td>F16HV 5A</td> <td>F17HV 10A</td> <td>F18HV 10A</td> </tr> <tr> <td>CR2HV</td> <td>CR3HV</td> <td>CR4HV</td> <td>CR5HV</td> <td>CR6HV</td> <td>CR7HV</td> </tr> <tr> <td>F12HV 5A</td> <td rowspan="2">CR8HV</td> <td rowspan="2">CR9HV</td> <td rowspan="2">CR10HV</td> <td rowspan="2">CR11HV</td> <td rowspan="2">CR12HV</td> </tr> <tr> <td>F11HV 10A</td> </tr> </table>	N/A	N/A	F19HV 10A	N/A	N/A	N/A	CR1HV		CR13HV		N/A		F10HV – 30A	F13HV 5A	F14HV 5A	F15HV 5A	F16HV 5A	F17HV 10A	F18HV 10A	CR2HV	CR3HV	CR4HV	CR5HV	CR6HV	CR7HV	F12HV 5A	CR8HV	CR9HV	CR10HV	CR11HV	CR12HV	F11HV 10A	F10HV	CF – Cooling fan	25A	Mini 32Vdc blade fuse
	N/A	N/A	F19HV 10A	N/A	N/A	N/A																														
	CR1HV		CR13HV		N/A																															
	F10HV – 30A																																			
	F13HV 5A	F14HV 5A	F15HV 5A	F16HV 5A	F17HV 10A	F18HV 10A																														
	CR2HV	CR3HV	CR4HV	CR5HV	CR6HV	CR7HV																														
	F12HV 5A	CR8HV	CR9HV	CR10HV	CR11HV	CR12HV																														
	F11HV 10A																																			
		F11HV	HEC – Electrification control unit	10A	Mini 32Vdc blade fuse																															
		F12HV	Logic, diagnostics	5A	Mini 32Vdc blade fuse																															
		F13HV	KL30HV: HV Battery logic, PDU, Charge wake-up	5A	Mini 32Vdc blade fuse																															
		F14HV	KL30HV: Inverter, HMI	5A	Mini 32Vdc blade fuse																															
		F15HV	KL30HV: Compressor, heater	5A	Mini 32Vdc blade fuse																															
	F16HV	HV Battery contactors	10A	Mini 32Vdc blade fuse																																
	F17HV	BCP – Battery coolant pump	10A	Mini 32Vdc blade fuse																																
	F18HV	CCP – Components coolant pump	10A	Mini 32Vdc blade fuse																																
	F19HV	K1HV, K2HV – Winch supply contactors	10A	Mini 32Vcd blade fuse																																
	RELAY No.	FUNCTION	RELAY TYPE	COMPONENT																																
	CR1HV	CF – Cooling fan	ISO 7588-1 Mini relay	Song Chuan 896H-1CH-S-R1-12VDC																																
	CR2HV	KL30HV: HV Battery logic, PDU, Charge wake-up	ISO 280 Ultra Micro	Song Chuan 303-1AH-C-R1 12 Vdc																																
	CR3HV	KL30HV: Inverter, HMI	ISO 280 Ultra Micro	Song Chuan 303-1AH-C-R1 12 Vdc																																
	CR4HV	KL30HV: Compressor, heater	ISO 280 Ultra Micro	Song Chuan 303-1AH-C-R1 12 Vdc																																
	CR5HV	HV Battery contactors	ISO 280 Ultra Micro	Song Chuan 303-1AH-C-R1 12 Vdc																																
	CR6HV	BCP – Battery coolant pump	ISO 280 Ultra Micro	Song Chuan 303-1AH-C-R1 12 Vdc																																
	CR7HV	CCP – Components coolant pump	ISO 280 Ultra Micro	Song Chuan 303-1AH-C-R1 12 Vdc																																
	CR8HV	INV/Motor HVIL circuit	ISO 280 Ultra Micro	Song Chuan 303-1AH-C-R1 12 Vdc																																
	CR9HV	FW Drive enable	ISO 280 Ultra Micro	Song Chuan 303-1AH-C-R1 12 Vdc																																
	CR10HV	REV Drive enable	ISO 280 Ultra Micro	Song Chuan 303-1AH-C-R1 12 Vdc																																
	CR11HV	Brakes enable	ISO 280 Ultra Micro	Song Chuan 303-1AH-C-R1 12 Vdc																																
	CR12HV	SW inhibit	ISO 280 Ultra Micro	Song Chuan 303-1AH-C-R1 12 Vdc																																
	CR13HV	K1HV, K2HV – Winch supply contactors	ISO 7588-1 Mini relay	Song Chuan 896H-1CH-S-R1-12VDC																																

ID.	FUNCTION
BAT1	High voltage primary battery
BAC	Battery A/C compressor
BCP	Battery coolant pump
BH	Battery heater
CC	Charge connector
CCP	Components coolant pump
CF	Cooling fan
CHA	Charger
CS	Current sensor
CT1	Components coolant temperature – cold side
CT2	Components coolant temperature – hot side
DISP	Battery State of charge display
FC	Cooling fan controller
HEC	Electrification control unit
HMI	User interface assembly
HVIL	High voltage interlock
INV	Inverter
ISO	Isolation monitoring unit
MSD	Manual Service Disconnect
K1HV, K2HV	Winch contactors
M1HV	Motor
PDM1HV	12Vdc Power Distribution Unit 1 for HV system
PDM2HV	12Vdc Power Distribution Unit 2 for HV system
PDU	Power Distribution Unit – high voltage
TM	Thermo module
Y1	Thermo module change over valve
Y2	Thermo module 2-way valve
Y3	Thermo module 2-way valve
Y4	Coolant valve

List of components

ID.	FUNCTION	COMPONENT
BAT1	High voltage primary battery	BorgWarner_OrionV1
BAC	Battery A/C compressor	Included in TM assembly
BCP	Battery coolant pump	Pierburg CWA100
BH	Battery heater	DBK_gen1p5sw1_heater
CC	Charge connector	Hybria A220513-001A
CCP	Components coolant pump	Pierburg CWA100
CF	Cooling fan	Part of radiator assembly Hydac AC-M4
CHA	Charger	Netpower_CA16K6-1AL
CS	Current sensor	LEM DHAB S133
CT1	Components coolant temperature – cold side	AB Elektronik Sachsen type 940097
CT2	Components coolant temperature – hot side	AB Elektronik Sachsen type 940097
DISP	Battery State of charge display	Curtis ICE914Z-2401
FC	Cooling fan controller	Hydac ESC
HEC	Electrification control unit	Bosch Rexroth_RC10-10/31
HMI	User interface assembly	Hybria A220512-001A
HVIL	High voltage interlock	-
INV	Inverter	Bosch Rexroth_INVCON3.3
K1HV, K2HV	Winch contactors	Gigavac GX14BAB
ISO	Isolation monitoring unit	Sendyne SIM100MOD
MSD	Manual Service Disconnect	Part of BAT1
M1HV	Motor	Bosch Rexroth SMG220
PDM1HV	12Vdc Power Distribution Unit 1 for HV system	Littelfuse PDM 880076
PDM2HV	12Vdc Power Distribution Unit 2 for HV system	Part of Electric Power Unit assembly A211108-001A, includes TE-connectivity fuse blocks 1443997-1 and 2297813-3
PDU	Power Distribution Unit – high voltage	Hybria A211108-004A
TM	Thermo module	Rheinmetall 400V V1
Y1	Thermo module change over valve	Included in TM assembly
Y2	Thermo module 2-way valve	Included in TM assembly
Y3	Thermo module 2-way valve	Included in TM assembly
Y4	Coolant valve	Bosch 1 147 412 207

Electric power unit

Electric Power Unit assembly drawing – component identification

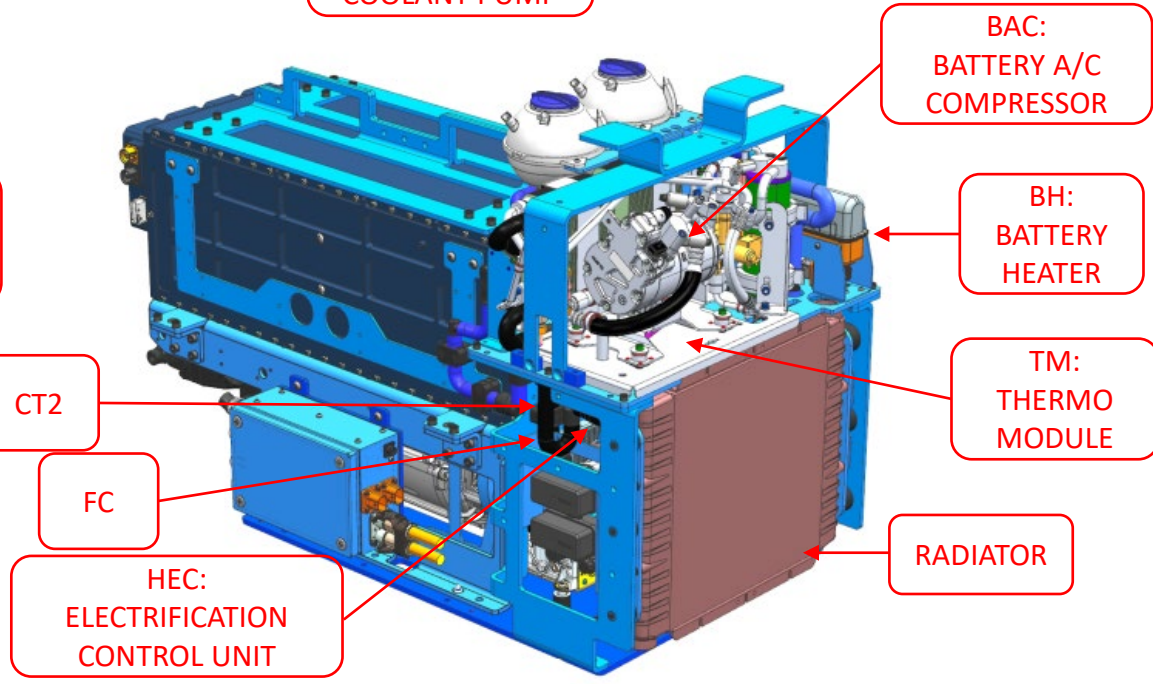
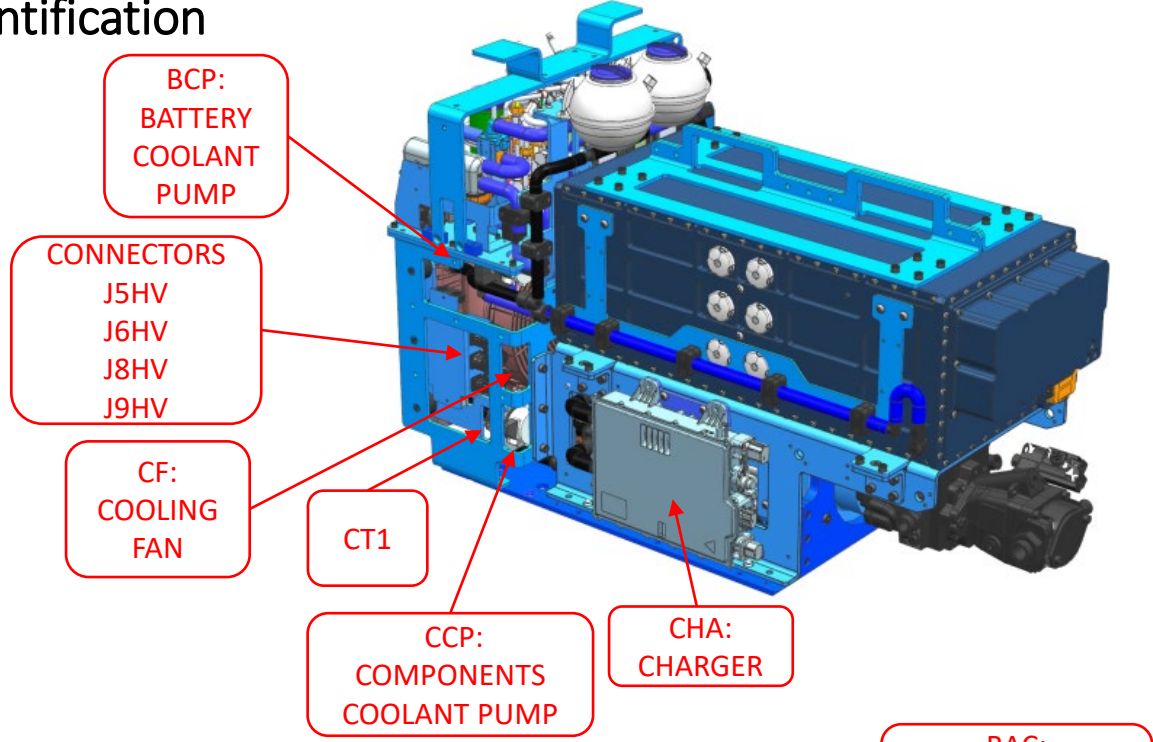
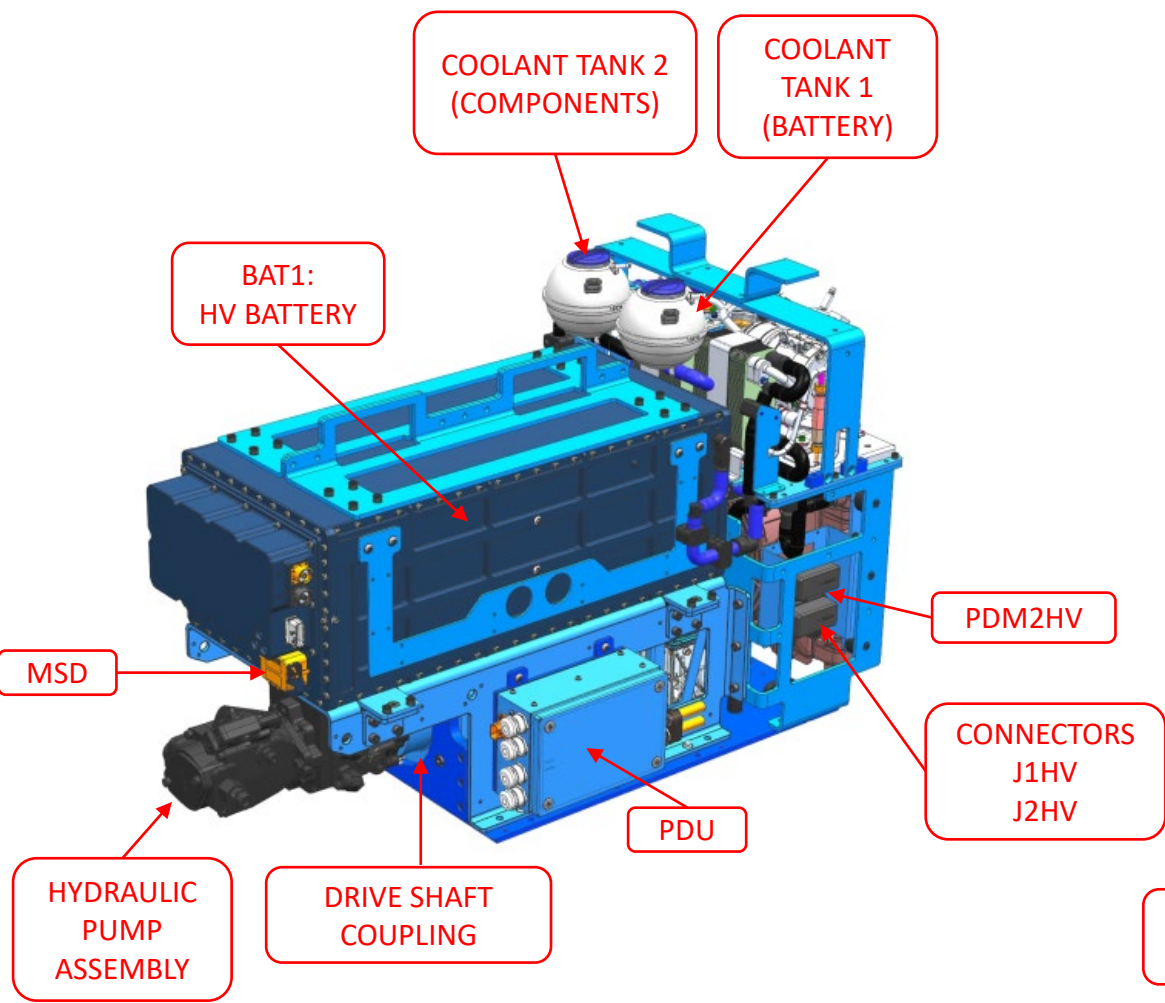

Electric Power Unit assembly drawing

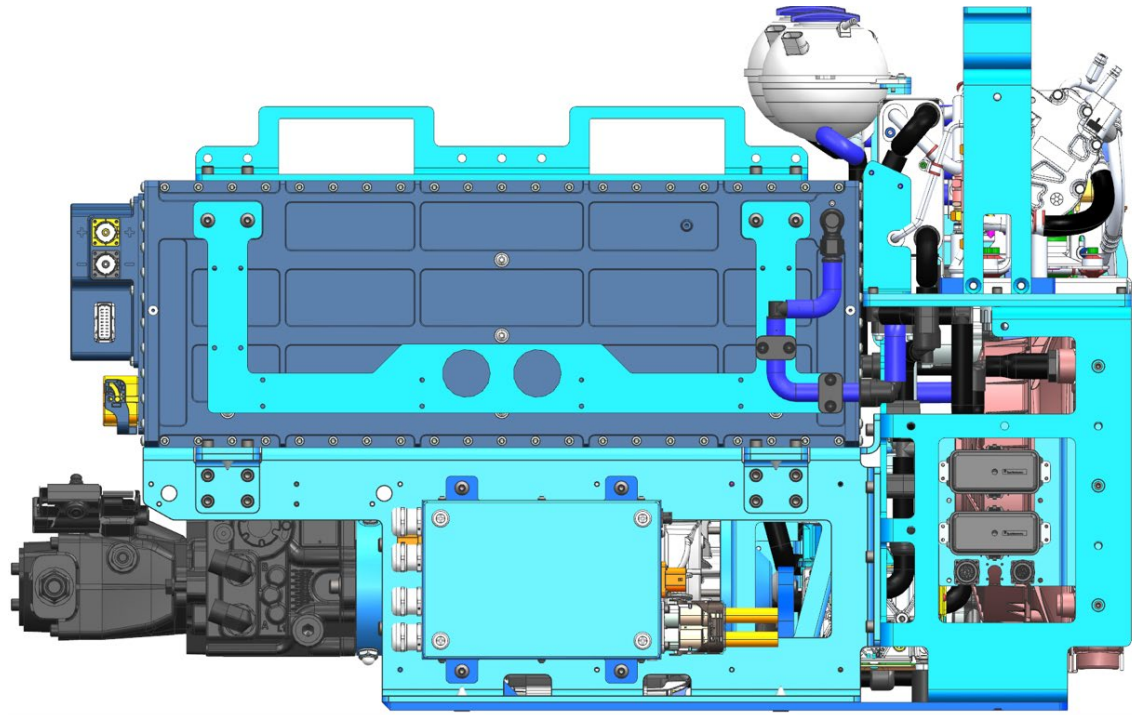

LEFT SIDE VIEW

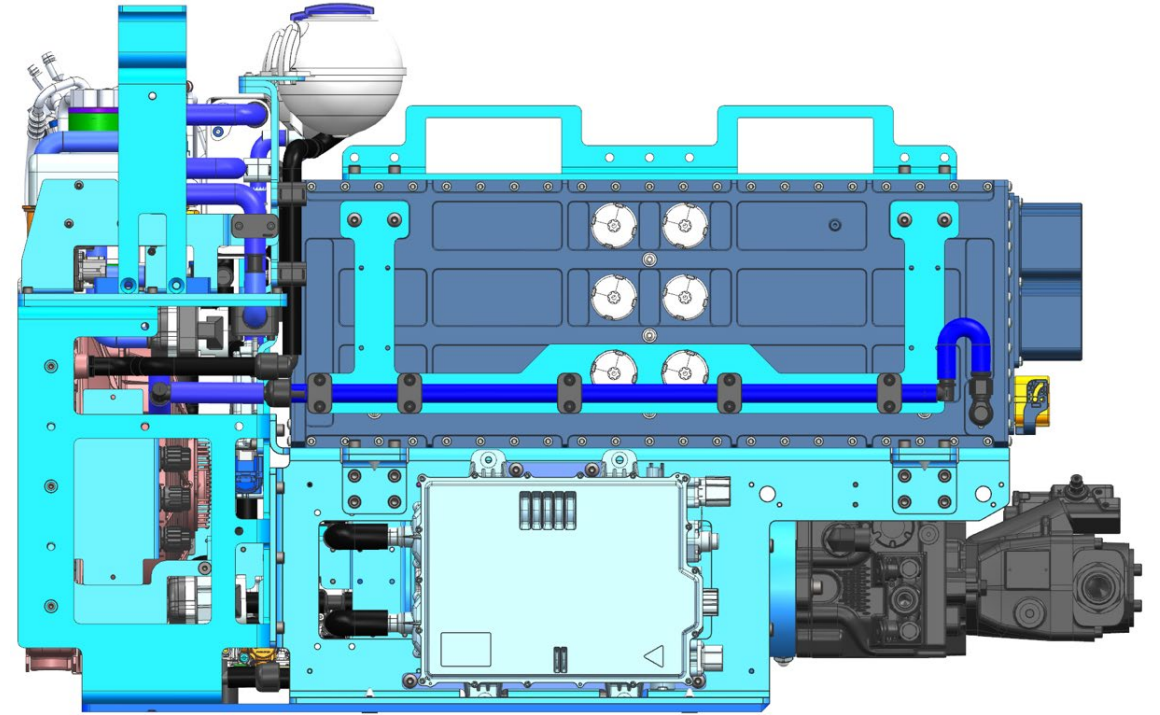

RIGHT SIDE VIEW

Electric Power Unit assembly drawing

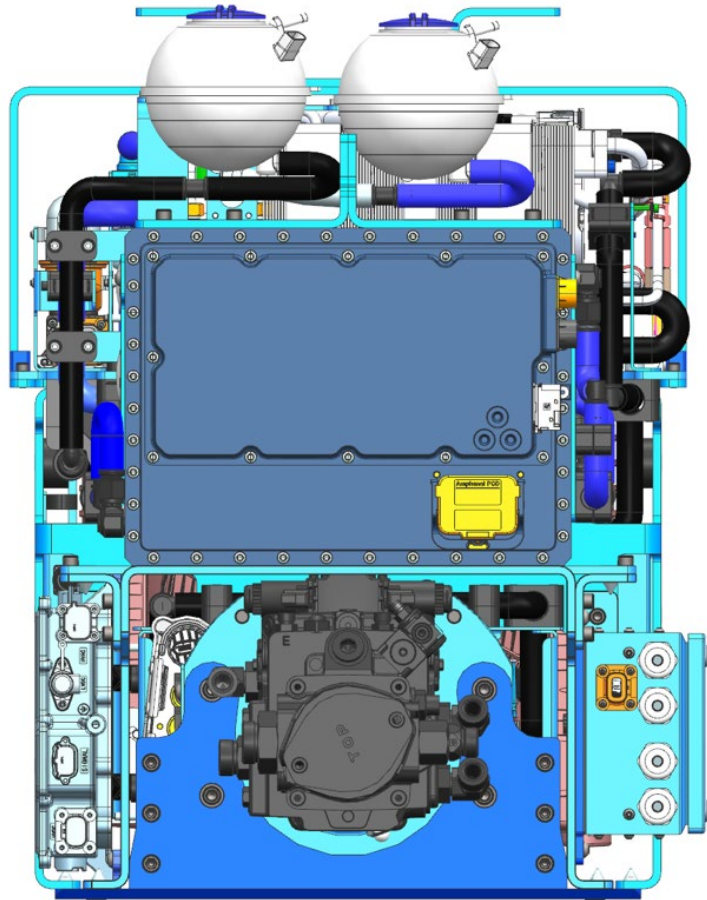

FRONT SIDE VIEW

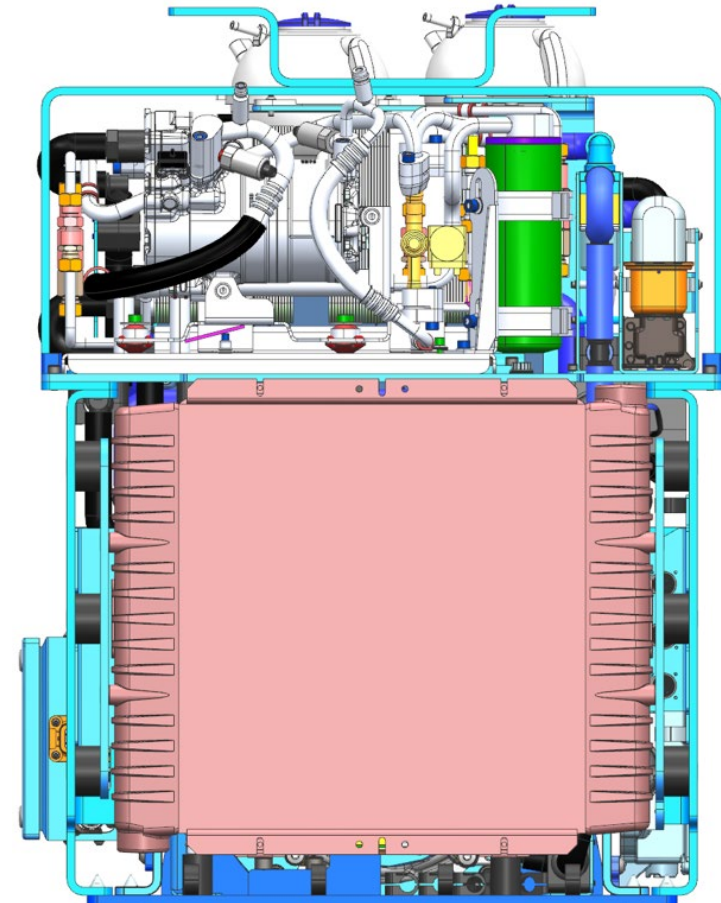

REAR SIDE VIEW

Electric Power Unit assembly drawing

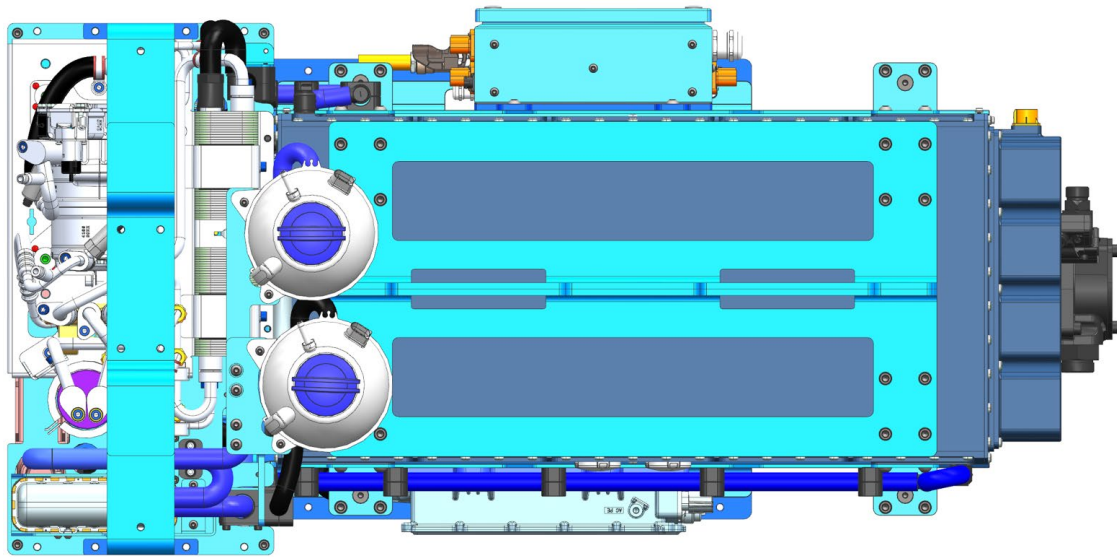

TOP SIDE VIEW

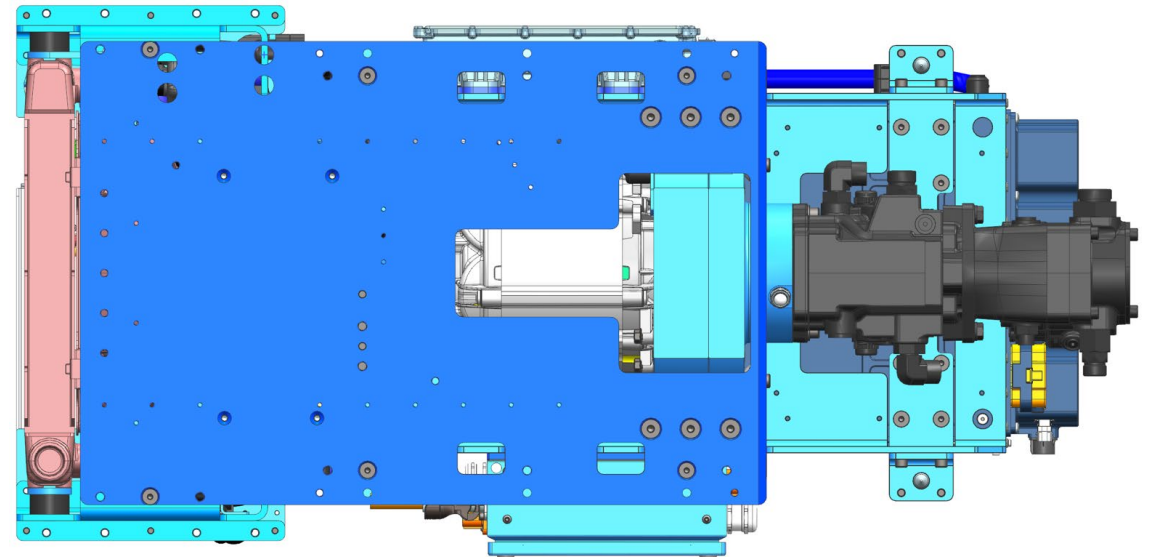

BOTTOM SIDE VIEW

HIGH VOLTAGE SYSTEM

HIGH VOLTAGE SYSTEM OVERVIEW

MSD – Manual Service Disconnect

MSD MUST BE REMOVED BEFORE ANY INSTALLATION IN HIGH VOLTAGE SYSTEM AND CABLING!



BAT1 - HIGH VOLTAGE BATTERY

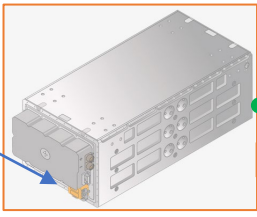

BAT1 +
70mm²

BAT1 -
70mm²

CHARGE INLET



J1772 TYPE 1
85-265Vac / max 32A

3x6mm²



CHA - CHARGER
Max charge power:
120Vac: 1,8 kw
240Vac: 6,0 kw

HVDC4
2x4mm²

PDU – POWER DISTRIBUTION UNIT

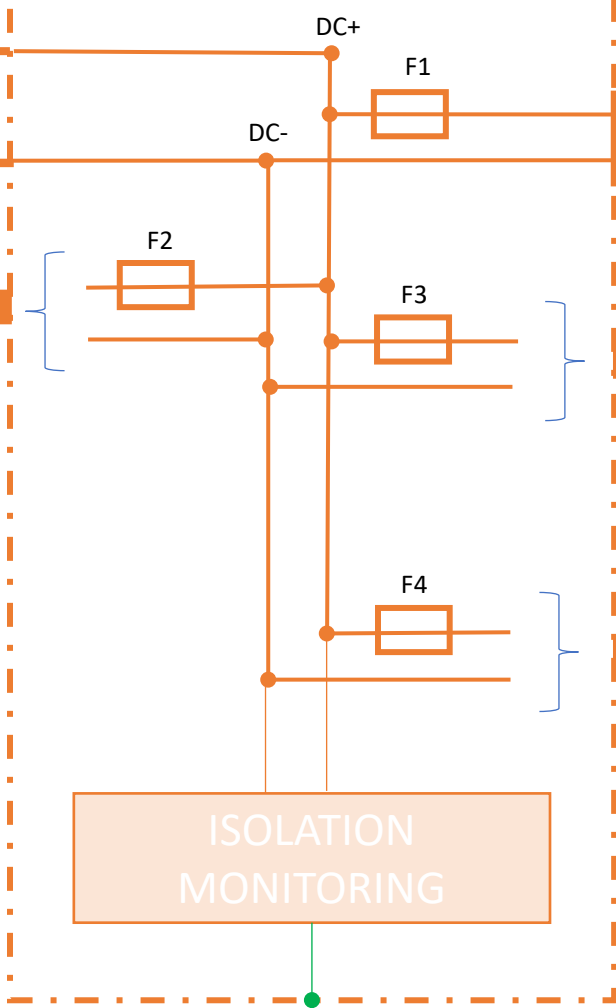

12 VDC SYSTEM



INV – INVERTER
DC/DC CONVERTER



M1HV - MOTOR



BAC – BATTERY
A/C COMPRESSOR



BH - BATTERY
HEATER

HVDC2
2x4mm²

HVDC3
2x4mm²

ISOLATION
MONITORING

VEHICLE CHASSIS

HV BATTERY INTERNAL CONNECTION

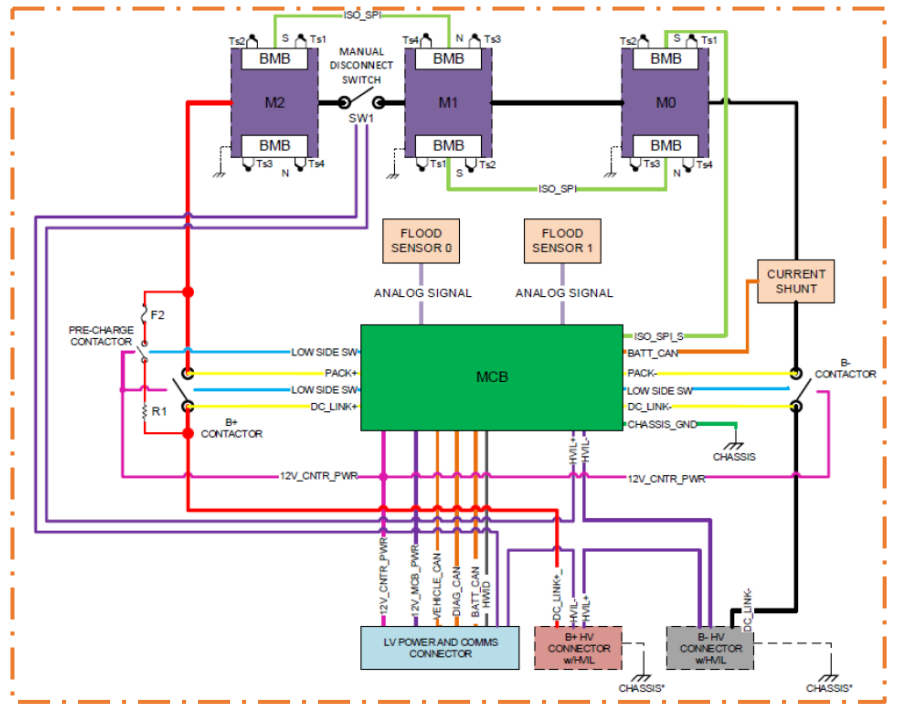

35mm²

35mm²

2,5mm²

2,5mm²

35mm²

35mm²

35mm²

PDU – Power distribution unit

FUSE No.	FUNCTION	RATING	COMPONENT
F1HV	Inverter	250A	Mersen MEV50A250-25G
F2HV	Charger	25A	Mersen MEV100C25
F3HV	HV compressor	25A	Mersen MEV100C25
F4HV	Battery heater	25A	Mersen MEV100C25

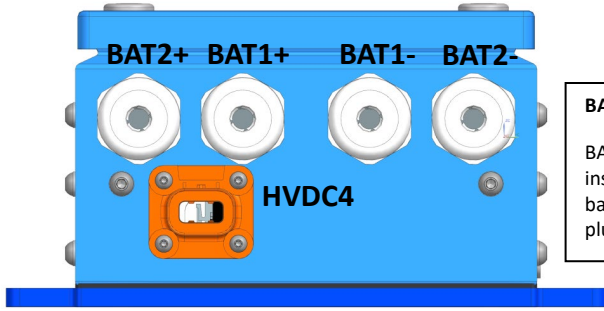
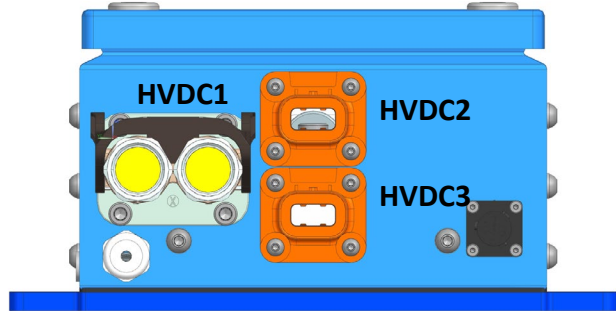
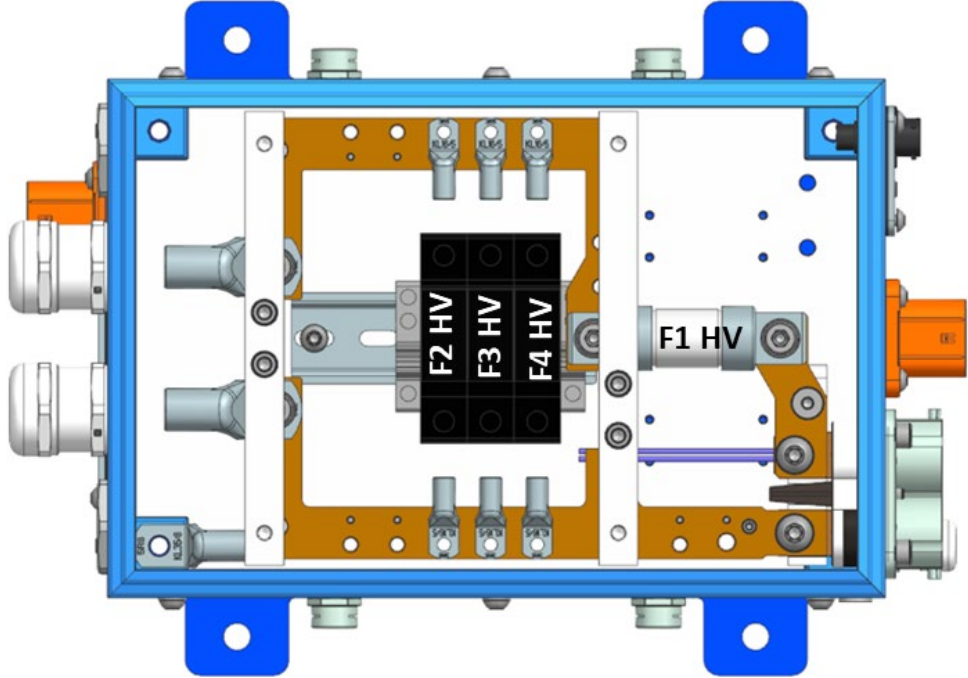
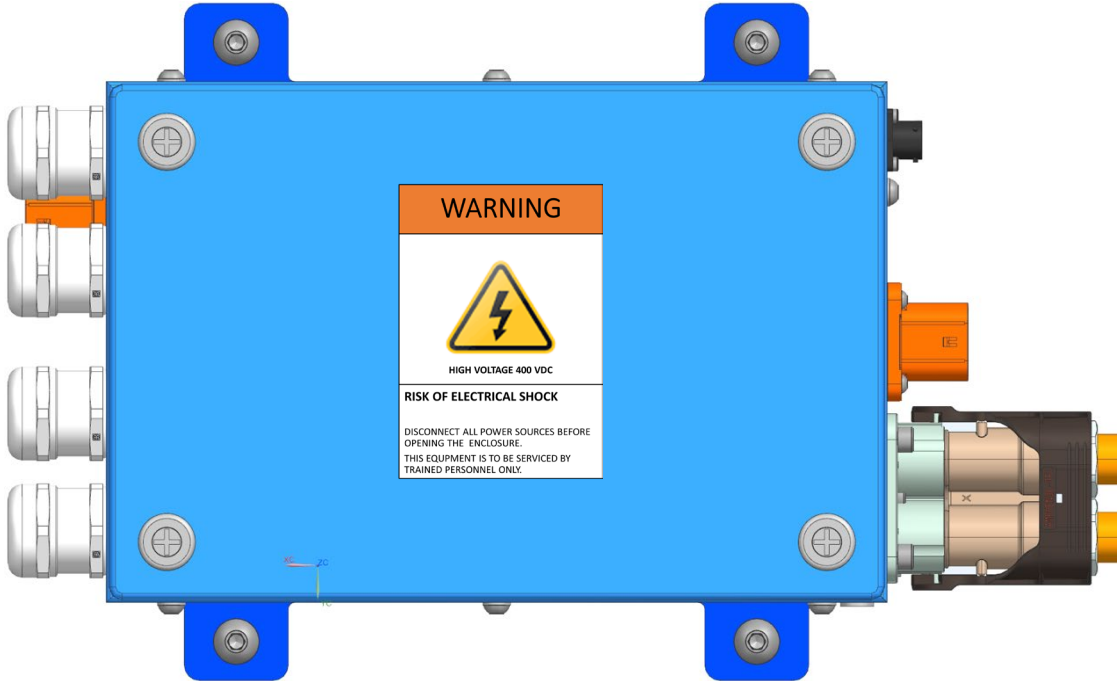

BATTERY CONNECTIONS
 BAT2+ and BAT2- cable glands are installed only if the secondary HV battery will be used otherwise plugged,

LOW VOLTAGE SYSTEM

12VDC Power Distribution Module 1 – PDM1HV

GENIE 12VDC SYSTEMS

CS – CURRENT SENSOR

Main Switch

ADDITIONAL 12VDC SYTEM LOADS
 Do not connect any 12VDC system loads on positive battery pole directly! Always use the B+ connection terminal in 12Vdc power distribution module, because otherwise the battery management may not work correctly.

3 x 32Vdc 200A
 MIDI® Style Bolt-down Fuse

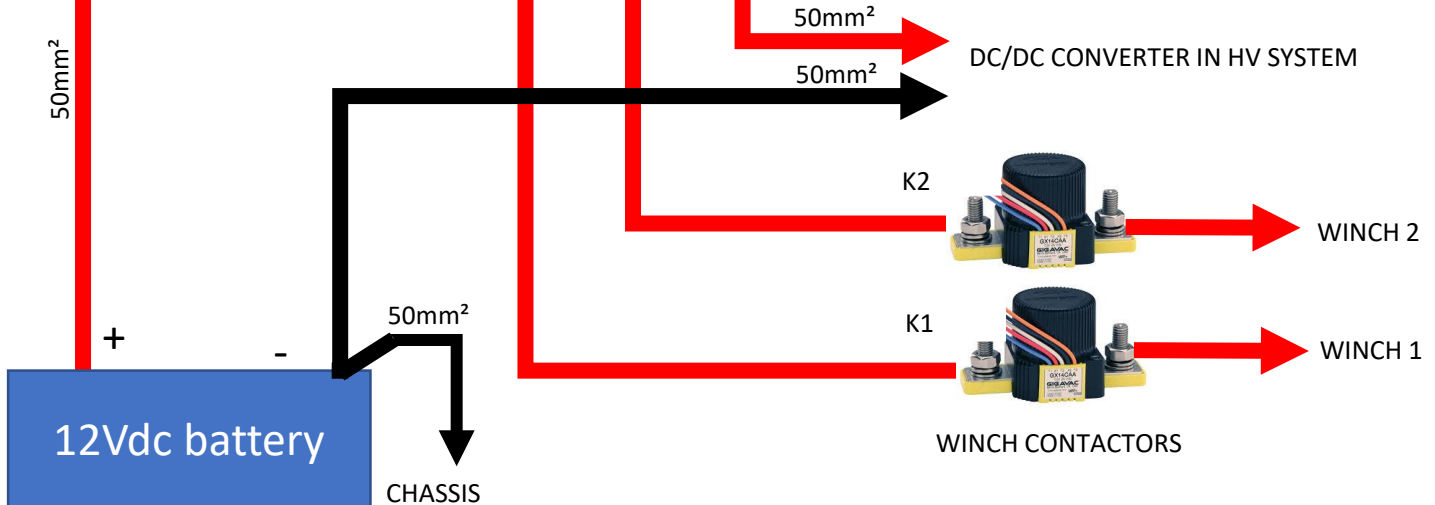
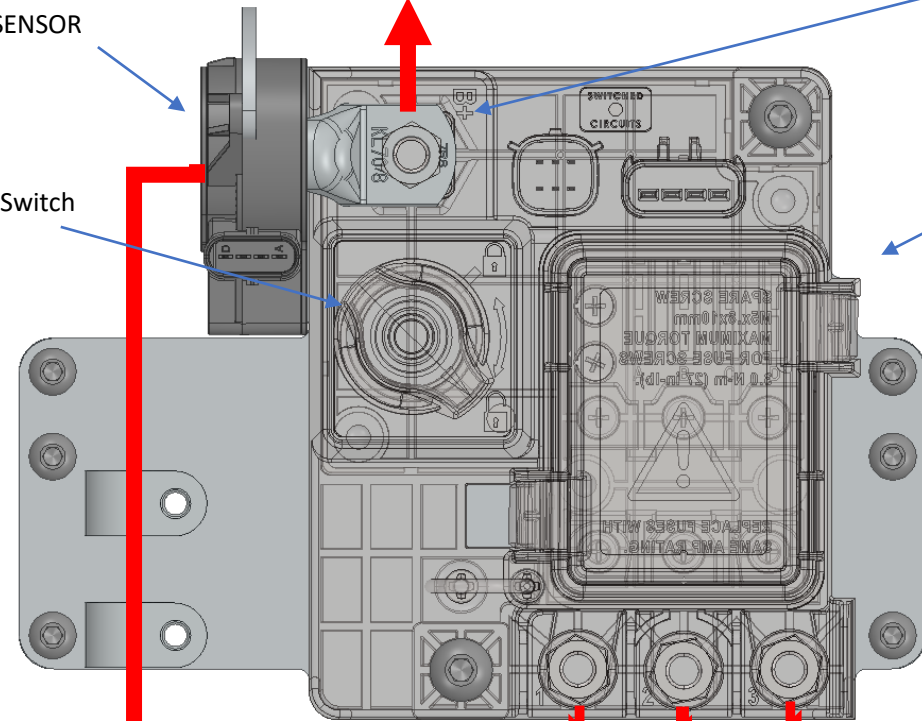
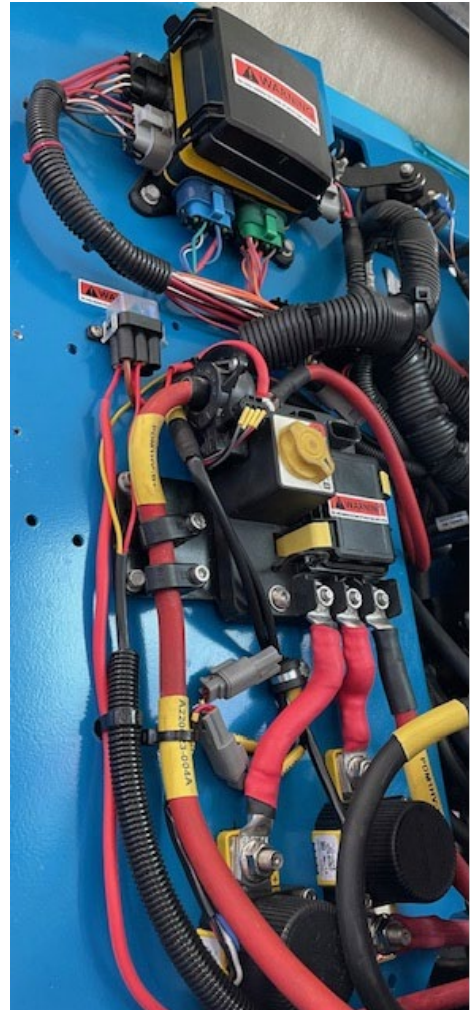

12VDC Power Distribution Module 2 – PDM2HV

N/A	N/A	F19HV	N/A	N/A	N/A
CR1HV		CR13HV		N/A	

F10HV – 30A

F13HV 5A	F14HV 5A	F15HV 5A	F16HV 5A	F17HV 10A	F18HV 10A
CR2HV	CR3HV	CR4HV	CR5HV	CR6HV	CR7HV
F12HV 5A	CR8HV	CR9HV	CR10HV	CR11HV	CR12HV
F11HV 10A					

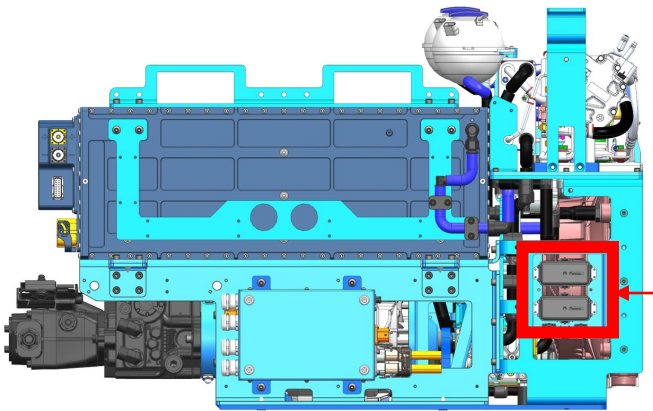

PDM2HV
LOCATION

FUSE No.	FUNCTION	RATING	COMPONENT
F10HV	CF – Cooling fan	30A	ATOF 32Vdc blade fuse
F11HV	HEC – Electrification control unit	10A	Mini 32Vcd blade fuse
F12HV	Logic, diagnostics	5A	Mini 32Vcd blade fuse
F13HV	KL30HV: HV Battery logic, PDU, Charge wake-up	5A	Mini 32Vcd blade fuse
F14HV	KL30HV: Inverter, HMI	5A	Mini 32Vcd blade fuse
F15HV	KL30HV: Compressor, heater	5A	Mini 32Vcd blade fuse
F16HV	HV Battery contactors	5A	Mini 32Vcd blade fuse
F17HV	BCP – Battery coolant pump	10A	Mini 32Vcd blade fuse
F18HV	CCP – Components coolant pump	10A	Mini 32Vcd blade fuse
F19HV	K1HV, K2HV – Winch supply contactors	10A	Mini 32Vcd blade fuse
RELAY No.	FUNCTION	RELAY TYPE	COMPONENT
CR1HV	CF – Cooling fan	ISO 7588-1 Mini relay	Song Chuan 896H-1CH-S-R1-12VDC
CR2HV	KL30HV: HV Battery logic, PDU, Charge wake-up	ISO 280 Ultra Micro	Song Chuan 303-1AH-C-R1 12 Vdc
CR3HV	KL30HV: Inverter, HMI	ISO 280 Ultra Micro	Song Chuan 303-1AH-C-R1 12 Vdc
CR4HV	KL30HV: Compressor, heater	ISO 280 Ultra Micro	Song Chuan 303-1AH-C-R1 12 Vdc
CR5HV	HV Battery contactors	ISO 280 Ultra Micro	Song Chuan 303-1AH-C-R1 12 Vdc
CR6HV	BCP – Battery coolant pump	ISO 280 Ultra Micro	Song Chuan 303-1AH-C-R1 12 Vdc
CR7HV	CCP – Components coolant pump	ISO 280 Ultra Micro	Song Chuan 303-1AH-C-R1 12 Vdc
CR8HV	INV/Motor HVIL circuit	ISO 280 Ultra Micro	Song Chuan 303-1AH-C-R1 12 Vdc
CR9HV	FW Drive enable	ISO 280 Ultra Micro	Song Chuan 303-1AH-C-R1 12 Vdc
CR10HV	REV Drive enable	ISO 280 Ultra Micro	Song Chuan 303-1AH-C-R1 12 Vdc
CR11HV	Brakes enable	ISO 280 Ultra Micro	Song Chuan 303-1AH-C-R1 12 Vdc
CR12HV	SW inhibit	ISO 280 Ultra Micro	Song Chuan 303-1AH-C-R1 12 Vdc
CR13HV	K1HV, K2HV – Winch supply contactors	ISO 7588-1 Mini relay	Song Chuan 896H-1CH-S-R1-12VDC

COOLING SYSTEM

COOLING SYSTEM OVERVIEW

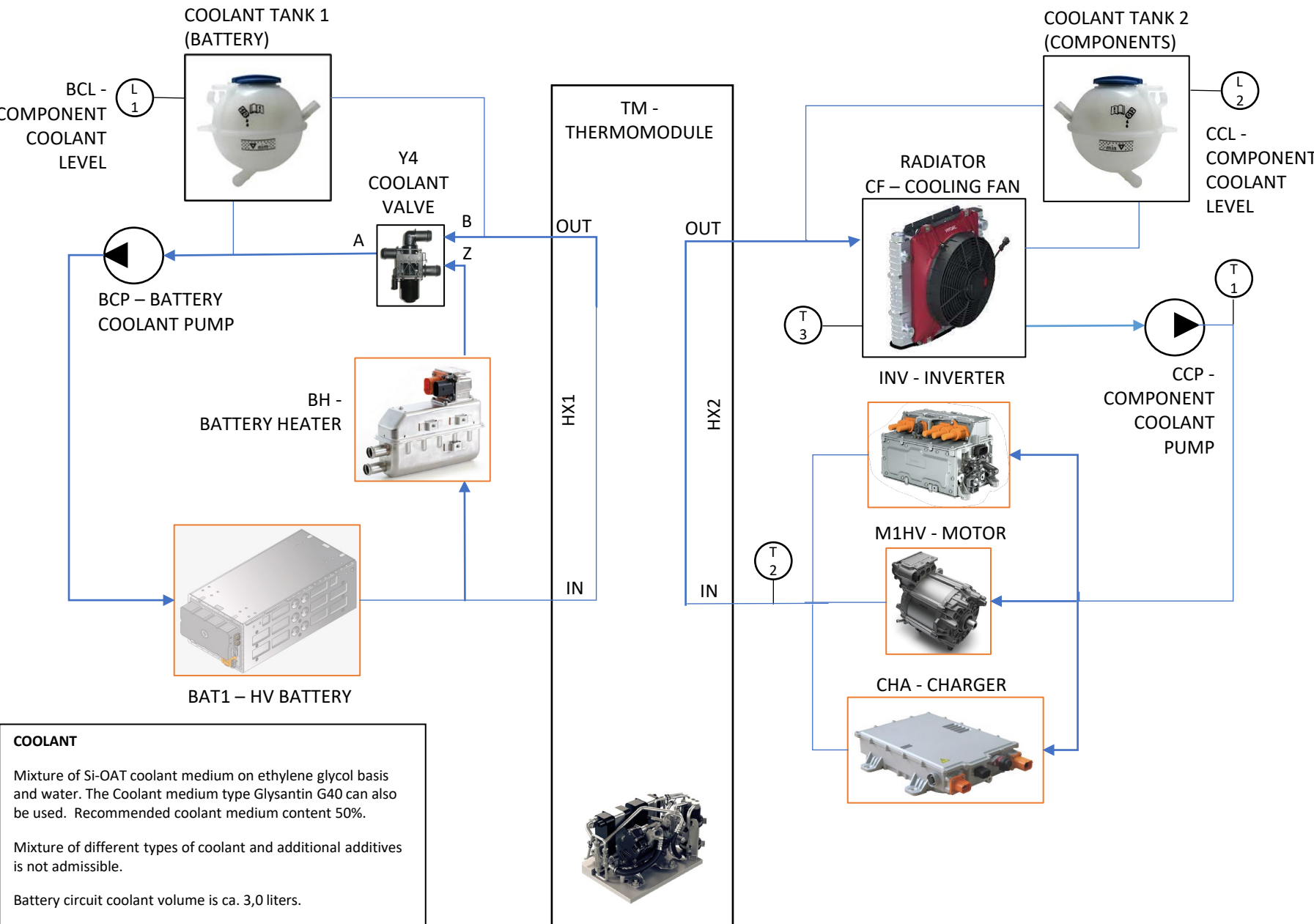

COOLANT

Mixture of Si-OAT coolant medium on ethylene glycol basis and water. The Coolant medium type Glysantin G40 can also be used. Recommended coolant medium content 50%.

Mixture of different types of coolant and additional additives is not admissible.

Battery circuit coolant volume is ca. 3,0 liters.

Components circuit volume is ca. 7,5 liters.

THERMOMODULE DETAILS

R-1234yf

WARNING: Use only PAGType SP A2 refrigeration compressor oil in R-1234 yf systems.

Do not mix PAG and standard synthetic compressor oils. Keep PAG compressor oil in tightly sealed containers. If PAG oil becomes contaminated with moisture or standard oils, dispose of properly—DO NOT USE.

When servicing unit, use only those service tools certified for and dedicated to R-1234 yf refrigerant and PAG compressor oils.

Residual non-HFC refrigerants or oils will contaminate R-1234yf systems.

Mode	0	1	2	3	Power consumption / valve
Output	off	Heating heat pump function	heating short circuit	cool mode	Watt
Y1	2 Reverse valve	0	0	1	10 W
Y2	3 Fujikoki 2 way valve	0	1	0	10 W
Y3	4 Fujikoki 2 way valve	0	0	1	10 W

HMI – USER INTERFACE

HMI – User interface

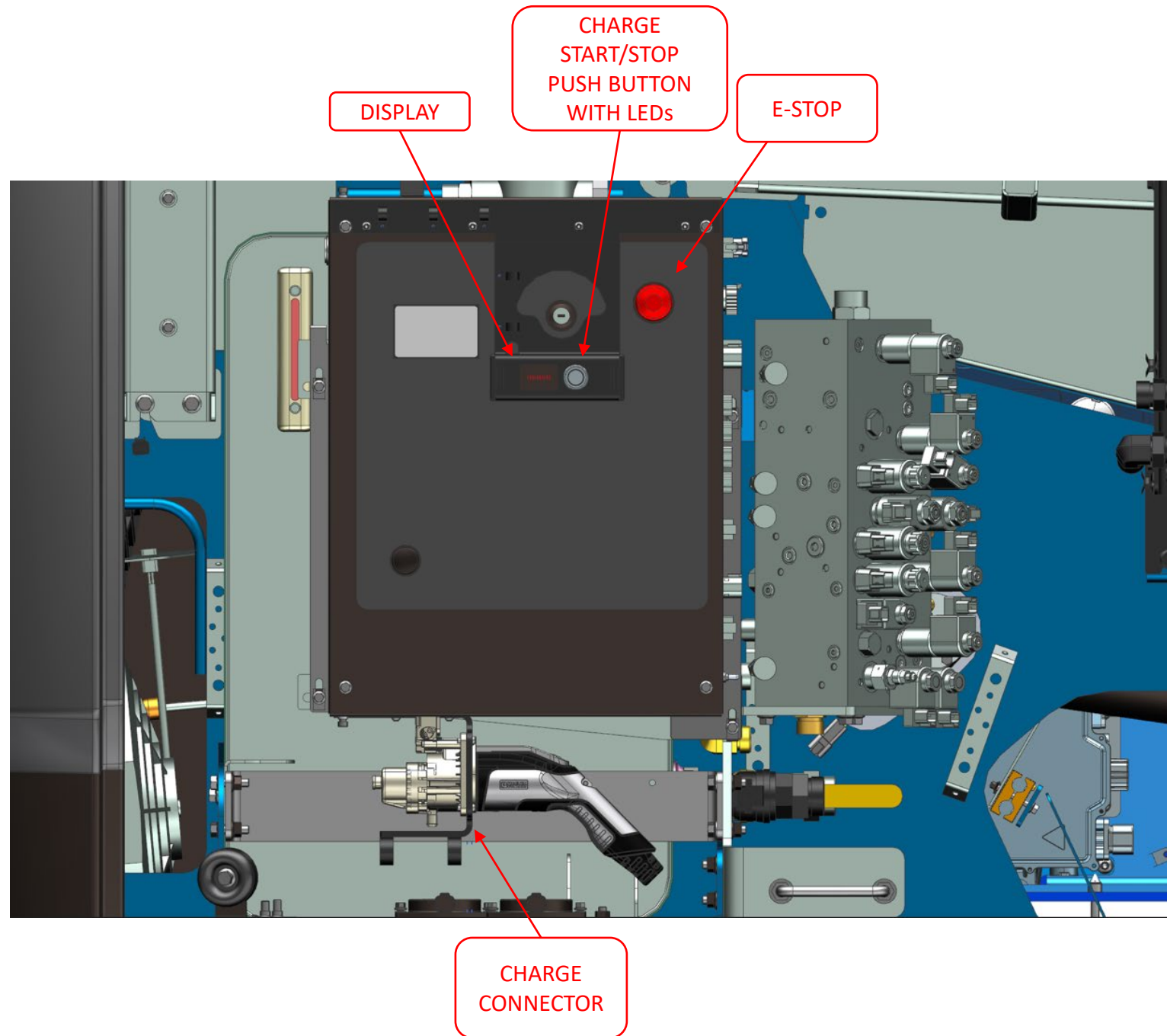

HMI – User interface

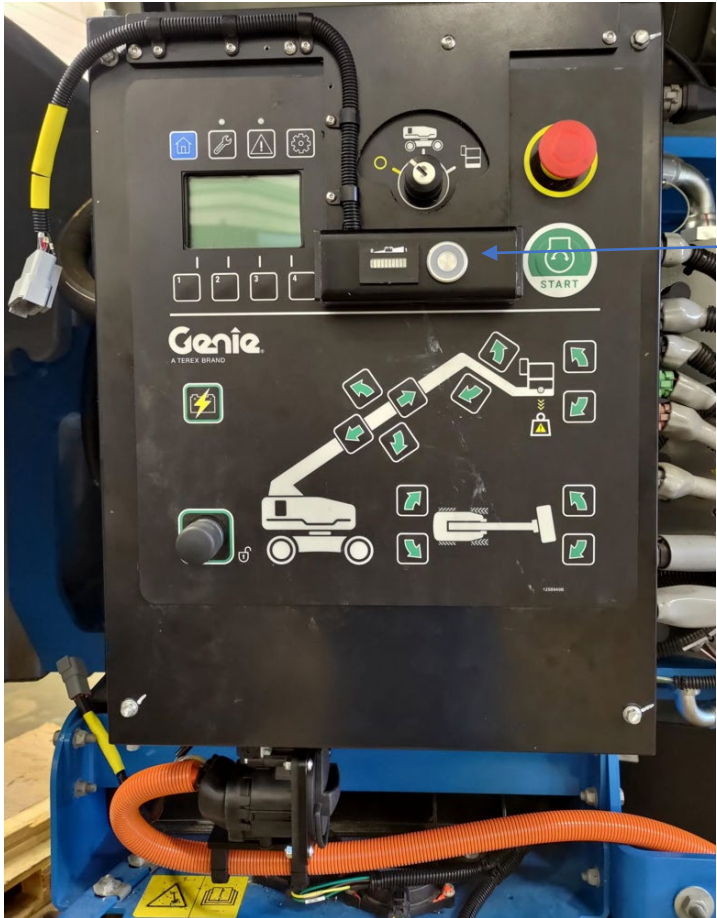

There is a multicolor LED (with red, green, blue light) for informing user about the status of the electric power pack.

In the middle of LED circle, there is a START/STOP CHARGING push button

Starting and stopping the system takes some time. Please wait until the system LED informs that the system is ready to start/stop until you take further action. It may need to learn new way of starting and stopping the operation modes.

LED STATES

Color	Blinking	Meaning
Off	Off	System is off and can be restarted
Blue	1 Hz, 50% duty cycle	System is starting up or shutting down. Please wait
Blue	1 Hz, short pulse	Ready to start. Waiting for start button to be pressed ("engine start")
Blue	Steady	System is operational
Green	1 Hz, short pulse	Charger cable is plugged. Waiting for charge button to be pressed to start charging.
Green	1 Hz, 50% duty cycle	Charging in progress and charge plug is locked
Green	Steady	Charge complete. Press charge button to finish charging and unlock charge plug.
Red	Steady	Error active. System is not operational. [machine alarm sound is also activated if that option is enabled in system parameters]

COMPONENTS:

Hybria AC and High voltage DC part:

!!!! = evidences very important

?= no information to this part available, maybe no evidence required if supply is limited or part of a other unit

N/A = not applicable, no evidence required

Place/ designation	Component description	data	Supply voltage	Evidence (certificate, report, ...)
BAT1	High voltage primary battery	BorgWarner_OrionV1	400Vdc output 12Vdc logical input	BMS specification: SE-REQS-017 Orion V1 BMS Specification Rev4.pdf Battery specification: SE-PRSP-017 Orion V1 Pack Specification Rev5.pdf Battery manufacturer have promised test results but nothing received by today!
BAC	Battery A/C compressor	Sanden	400Vdc input 12Vdc logical input	ECE R10: ECE R10 Certificate 3143 ~ Customer Release.pdf Specification: SES-EC-854.pdf 3.9 Insulation and Voltage withstanding Insulation resistance at end of the test: Min 5MOhm at 500V DC supplied between HV terminal and compressor body Voltage withstand : AC 1900V (rms) during one minute.
BCP	Battery coolant pump	Pierburg CWA100	12Vdc input	Datasheet: CWA100_EN.pdf Typical automotive pump from after market
BH	Battery heater	DBK_gen1p5sw1_heater	400Vdc input 12Vdc logical input	Drawing: 000670680_se01a_wh_itm.pdf Test report summary: Electrical tests_overview.pdf

				EMC: EMC_Test_overview.pdf
CC	Charge connector	Phoenix Contact 1271960		CE: 1271960_CE_00.pdf Datasheet: phoenix-contact-1271960-en.pdf Test report summary: 2022 10 07 PBA 21045 Uni Inlet Gen4 AC T1.pdf
CCP	Components coolant pump	Pierburg CWA100	12Vdc input	See BCP
CF	Cooling fan	Part of radiator assembly Hydac AC-M4	12Vdc input	Specification: AC-M4_12V_PC.pdf Drawing: 4348325-DRW.PDF Brochure: AC-M-Brochure.pdf Typical 12Vcd automotive fan. Supplied by motor controller (FC) with current limit and fuse protection.
CHA	Charger	Netpower_CA16K6-1AL	85-265Vac input 400Vdc output 12Vdc logical input	Specification: CA16K6-1AL_datasheet.pdf Qualification test report: CA16K6-1AL Qualification Test Report.pdf Manufacturer is not willing to send test reports to us!
CS	Current sensor	LEM DHAB S133	5Vdc logical input from ECU	Datasheet: dhab_s_133.pdf
CT1	Components coolant temperature – cold side	AB Elektronik Sachsen type 940097	5Vdc logical input from ECU	Datasheet: DSAH00149.pdf Typical NTC type automotive coolant temp sensor
CT2	Components coolant temperature – hot side	AB Elektronik Sachsen type 940097		see CT1

DISP	Battery State of charge display	Curtis ICE914Z-2401	12 Vdc logical input	Datasheet: 0900766b80654b7b.pdf Drawing: 0900766b80654b85.pdf CE: Curtis_dec of conformity.pdf
FC	Cooling fan controller	Hydac ESC	12 Vdc logical input	Datasheet: ESC ACCESSORY.pdf
HEC	Electrification control unit	Bosch Rexroth_RC10-10/31	12 Vdc logical input Current limited 5Vdc output for sensors	EC: EC_declaration_of_comformity_RC10_10_31.pdf Manual: re95206_2016-02_RC1010_31.pdf Bosch Rexroth can send a qualification test summary and compare relevant standards with UL standards, but they will not send test results to us.
HMI	User interface assembly	Hybria A220512-001A	12vdc logical input	See DISP This is mechanical assembly including a display and pushbutton. All components work on 12vdc level.
HVIL	High voltage interlock	-	12vdc logical input	See schematic This is a safety wiring circuit, not a component.
INV	Inverter	Bosch Rexroth_INVCON3.3	400Vdc input 3-phase output for motor 12Vdc output	Drawing: F037A00631_01_AGZ_INVCON3_3_Ver.SMG220.pdf Technical documentation: F037S07257_TCD_INVCON3.3_OHW_V2_0_EN.pdf CE: F037300202_EU_Declaration_of_Conformity_INVCON3.3.pdf Validation test summary: INVCON_Gen3_VARO_Tests.pdf Bosch Rexroth can send a qualification test summary and compare relevant standards with UL standards, but they will not send test results to us.
ISO	Isolation monitoring unit	Send	12 vdc logical input	Datasheet: Sendyne SIM100MOD Datasheet V0.9.pdf

		yn e SI M1 00 M OD	400Vdc voltage measurement	Isolation monitoring unit is a PCB installed in PDU (Hybria A211108-004A). Is any data needed?
MSD	Manual Service Disconnect	Amphenol MINIMSDM400 Part of BAT1	400Vdc circuit	See BAT MSD specification: minimsd-rev-b-cdr.pdf MSD switch is part of the battery assembly. Manufacturer does not provide any qualification data.
M1HV	Motor	Bosch Rexroth SMG220	HV motor phase input 12Vdc logical input	Drawing: F037A00600_AGZ_SMG220_OHW.pdf Technical documentation: F037S07251_TCD_SMG220_OHW_V1_0_EN.pdf CE: F037S07279_EU_Declaration_of_Conformity_SMG220_OHW.pdf End of line test reports: F03ZY00495_01_PRV_el_Endprüfung_SMG_freiggegeben.pdf F03ZY00528_01_PRV_EOL_TREX_SMG_sigBrBgMi.pdf Bosch Rexroth can send a qualification test summary and compare relevant standards with UL standards, but they will not send test results to us.
PDM1HV	12Vdc Power Distribution Unit 1 for HV system	Littelfuse PDM 880076	12Vdc	Datasheet: Littelfuse_880076.pdf Drawing: Littelfuse_880076_CAD.pdf This is a main switch for 12Vdc. In also includes main fuses for winches and 12Vdc DC/DC converter. Is some data needed?

PDM2HV	12Vdc Power Distribution Unit 2 for HV system	Part of Electric Power Unit assembly A211108-001A, includes TE-connectivity fuse blocks 1443997-1 and 2297813-3		<p>Drawings:</p> <p>ENG_CD_1443997_R1.pdf</p> <p>ENG_CD_2297813_B.pdf</p> <p>Manufacturer does not send any qualification data!</p>
PDU	Power Distribution Unit – high voltage	Hybria A211108-004A	<p>400Vdc power distribution</p> <p>12Vdc logical input</p>	<p>This is an assembly including following components</p> <ul style="list-style-type: none"> - Rittal (UL approved) - Fuse holders UK10.3-HESI N (phoenix Contact) (UL approved) - Fuse F1 MERSEN MEV50A250-25G (see Fuse F1) - Fuses F2-F4 MERSEN MEV100C25 (UL recognised?) - Isolation monitoring unit (See ISO) <p>See relevant documentation for components.</p> <p>Is some data needed or is this covered by earlier evaluation?</p>
TM	Thermo module	Rheinmetall 400V V1	<p>400VDC input for compressor</p> <p>12 and 5Vdc inputs for control logic and sensors/actuators</p>	<p>Whats that? Heater? Or fluid system with valves (refer Y1... → what is supply voltage?)</p> <p>IF 400V supply, than evidence required.</p> <p>Only compressor is supplied from 400Vdc. See BAC.</p>
Y1	Thermo module change over valve	Included in TM assembly	12Vdc	Refer above
Y2	Thermo module 2-way valve	Included in TM assembly	12Vdc	Refer above
Y3	Thermo module 2-way valve	Included in TM assembly	12Vdc	Refer above

Y4	Coolant valve	Bosch 1 147 412 207	12Vdc	Refer above
FUSEHOLDE R F2...F4	Fuseholder	UK10.3-HESI N (phoenix Contact)	400Vdc	E244294 (UL) 225908 (CSA) Is this okay?
Fuse F2...F4	DC Fuse	MERSEN MEV100C25 (1000VDC max 25A)	400Vdc	UL regonized (marking on fuse, no certficate available) Is this okay?
Fuse F1	DC Automotive Fuse	MERSEN MEV50A250-25G	400Vdc	NO MARKING, NO INFORMATION Approval required. No UL approval is available for this automotive fuse. However, there is same fuse for industrial use with different product code (ABAT5M250-25G) in UL approval process, which should be completed by end of November 2022. It is confirmed by the manufacturer, that MEV50A250-25G and ABAT5M250-25G are physically and electrically same fuse. The difference is that they have different certification and different quality control requirements in production line. CE: COM-CE-CE0001-MEV100C-Mersen.pdf Specification for both fuses to be compared: DS-EVpack-fuse-MEV100-1000VDC-EN.pdf Mersen - ABAT5M.pdf Approval document for ABAT5M250-25G: COM-UL-certificate-E523293v1s2-ABAT5AM fuses.pdf Test data available under NDA only!

Cables	Orange Cables (for AC from supply and DC)	?????		<p>!!!! approval required!</p> <p>400Vdc battery cables HEW Kabel</p> <ul style="list-style-type: none"> - PDU to BAT1 - Cable product HEW 70393 <ul style="list-style-type: none"> o No UL approval o Performance in Data sheet: 43093-70.pdf o 600Vdc acc. ISO-6722 - Road vehicles, 60 V and 600 V single-core cables o ISO LV-216 - Shielded high-voltage sheathed cables for motor vehicles and their electrical drives o IEC 60332-1-2004-07 - Tests on electric and optical fibre cables under fire conditions - Part 1-2: Test for vertical flame propagation for a single insulated wire or cable - Procedure for 1 kW pre-mixed flame <ul style="list-style-type: none"> o Manufacturer will not send test data! - Refer to data sheet. No test data available! <p>400Vdc cable for compressor</p> <ul style="list-style-type: none"> - PDU to BAC - cable assembly Hirschmann 908-147-A33 Typ C <ul style="list-style-type: none"> o No UL approval o drawing HV_cable_908-147-A33 Typ C.pdf o Cable type: KROSCHU RH 64997213 FHRLR2GCB2G 2x6 QMM/0,31/T180 <ul style="list-style-type: none"> ▪ 1000 Vdc ▪ No feedback from the manufacturer yet <p>400Vdc cable for heater</p> <ul style="list-style-type: none"> - PDU to BH <ul style="list-style-type: none"> o No UL approval o cable assembly TE Connectivity 5-2208102-3 o drawing Gegenstecker-HV_ENG_CD_2208102_C1.pdf
--------	---	-------	--	---

- Cable type: KROSCHU RH 64994093 FLR52YCF2G 2x4sn+2x0.5sn/T180
 - 1000 Vdc
 - No feedback from the manufacturer yet

400Vdc cable for charger

- PDU to CHA
 - No UL approval
 - cable assembly TE Connectivity 1-2208103-3
 - drawing HVDC cable - TE Connectivity 1-2208103-3.pdf
 - Cable type: Coroflex CFM 9-2641 FHRL2GCB2G 2x4,0mm2/T180
 - cable specification: TBD
 - ISO LV-216 - Shielded high-voltage sheathed cables for motor vehicles and their electrical drives
 - 1000 Vdc
 - No feedback from the manufacturer yet

400Vdc for inverter/motor

- No UL approval
- Cable type: Coroflex CFM 9-2611 FHRL2GCB2G 50mm2/T180
 - cable specification: TBD
 - ISO LV-216 - Shielded high-voltage sheathed cables for motor vehicles and their electrical drives
 - 1000 Vdc
 - No feedback from the manufacturer yet

400Vdc PDU internal wiring

- Supply from F2-F4 to connectors
 - TE Connectivity 55A0111-12-3 (12 AWG)
 - specification: NG_CD_55A0111_R-668425.pdf
 - 600Vdc
 - ETFE insulation
 - No feedback from the manufacturer yet

- Isometer DC+ and DC- measurement
 - o Alpha wire 1557 16 AWG)
 - o specification: 2343796.pdf
 - o 1000Vrms/80 °C acc. MIL-W-76B TYPE MW
 - o **No feedback from the manufacturer yet**

AC from charge inlet to charger

- Leoni Silitherm FHRL2G2GCB2G00006 3x6

Europe – VDE and EN 50620 approval

Charging systems according to IEC 61851 for 1-phase and 3-phase charging

- nominal voltage 450 V AC / 750 V AC / max. 1000 V DC
- nominal current up to 200 A
- operating temperature –40 °C up to +90 °C

America – UL/cUL approval

Charging cables according to NEC Art. 400 and UL/cUL category FFSO (UL62) well as CSA C22.2 No.49 for 1-phase charging

- nominal voltage 300 V AC (EVJE), 1000 V DC (EVE)
- nominal current up to max. 80 A
- operating temperature –40 °C up to +105 °C

-

				<ul style="list-style-type: none"> - Isometer DC+ and DC- measurement <ul style="list-style-type: none"> o Alpha wire 1557 16 AWG) o specification: 2343796.pdf o 1000Vrms/80 °C acc. MIL-W-76B TYPE MW o No feedback from the manufacturer yet <p>AC from charge inlet to charger</p> <ul style="list-style-type: none"> - Leoni Silitherm FHRL2G2GCB2G00006 3x6 <div style="border: 1px solid black; padding: 5px; margin-bottom: 5px;"> <p>Europe – VDE and EN 50620 approval</p> <p>Charging systems according to IEC 61851 for 1-phase and 3-phase charging</p> <ul style="list-style-type: none"> ▪ nominal voltage 450 V AC / 750 V AC / max. 1000 V DC ▪ nominal current up to 200 A ▪ operating temperature –40 °C up to +90 °C </div> <div style="border: 1px solid black; padding: 5px;"> <p>America – UL/cUL approval</p> <p>Charging cables according to NEC Art. 400 and UL/cUL category FFSO (UL62) well as CSA C22.2 No.49 for 1-phase charging</p> <ul style="list-style-type: none"> ▪ nominal voltage 300 V AC (EVJE), 1000 V DC (EVE) ▪ nominal current up to max. 80 A ▪ operating temperature –40 °C up to +105 °C </div> <p>-</p>
	Control box	Rittal		UL approved

DC fuseholder				UL approved
F1	DC fuse	Mersen		!!!!!! no approval visible or in the documents!!! → website with on such fuses See F1
F2...5	DC fuse	Mersen		UL recognized
COMPONENTS				
12VDC system				
interchangeable	Battery	Lead accid, 12V 120Ah		UL recognized (foto)
	Pump (hydraulic lift system)			Tested within appliance (temperature, construction full metal enclosed)
	Battery cable (12V)	PVC cable, 450/750V, 70C/150C short circuit 5 sec	12Vdc	Battery cable, no approval mark Cable used in cabling between DC/DC converter (INV) and PDM1HV as well as between 12Vdc battery and PDM1HV. <ul style="list-style-type: none"> - Manufacturer BATT Cables PLC - Specification: BATT Cables Hi-Flex PVC 450_750 19040.pdf - No feedback from the manufacturer yet
	Winches (5 units)			Tested within appliance (temperature, construction full metal enclosed)
	Winch control cabinet	Cervis Inc. USA, UL listed		UL listed

	Remote control unit	Cervice "SmaRT" BU-xH16R (900Mhz, 2.4 GHz Base unit)		!!!! No approval visible, no FCC visible (but radio control)
K1HV, K2HV	Winch Supply Contactors NEW COMPONENTS!	Gigavac GX14BAB		The GX14 is UL released for the following ratings: <ul style="list-style-type: none"> 230vdc, 240A for 6k cycles (Make/break) 600Vdc, 200A for 6k cycles (Make/break)  sensata-gigavac-gx 14-series-open-cont

Components

Supply site and others

Charging booster set (with NEMA plug and wiring)	Charging booster	JUICE, type J+booster 2, 85-240VAC, NEMA plug, 9,6kW, outdoor		UL listed (cetificate missing or UL marking must be visible on product → not available now) Found in database: E524307 (for model no.: 08910/010600) Original part replaced with UL approved one.
Cable protection/ E-chain	Off-shore cable protection tubes (required for harbour)	TRIFLEX, V-2, V-0,		CSA, UL, TUV approved
EMO switches	Within control part (12V)			UL approved

Cover (side)	Cover (side), opening with key	Glas fibre material		Tested with appliance Gas flame 30sec, self extinguishing
Luminaire	LED luminaires	12VDC supplied		Tested with appliance (thermal test, construction check)



QTY	ITEM NUMBER/BIN	DESCRIPTION	MANUFACTURING PART NUMBER OR DRAWING NUMBER	REV LEVEL	COMMENTS
BASE UNIT					
10	1	BU-9X16R-EXT-LVD-NOS-CAN	BASE UNIT, 900 MHz, 100 mW, EXTERNAL ANTENNA, NO TRANSIENT SUPPRESSION, CAN	07318516	0-0
PISTOL GRIP					
20	1	PG-9X14-UMB-EXT	PISTOL GRIP, 900 MHz, 100MW, UMBILICAL, EXTERNAL ANTENNA	23260501	0-2
30	1	CU-GPH-LBL	CUSTOM GRAPHIC LABEL	WSMB-11456_LBL	0-0
OTHER ITEMS					
40	1	HN-1006	BASE UNIT CABLE ASSEMBLY, GREEN/BROWN CONNECTORS, 3 FT		
50	1	EXT-3-900	900 MHz ANTENNA EXTENSION KIT, INCLUDES 3" CABLE (J5-07) AND ANTENNA (BB3-06)		
60	1	BB3-06	900 MHz ANTENNA		
70	1	C4-20	50FT HANDHELD TETHER CONNECTION KIT (C6-12, C6-12, C6-13, C4-14)		
DOCUMENTATION					
80	1	SYSTEM DESIGN DOCUMENT		WSMB-11456	0-0
90	1	BU-xH16R MANUAL		U095.1.1	
100	1	PG-x14 MANUAL		U045.12.0	

-- REVISIONS --

NO.	DATE	DESCRIPTION
A-0	09/27/2023	(ECJ) APPROVAL RELEASE

CUSTOMER: HYBEKO AS		
DESCRIPTION: SYSTEM BILL OF MATERIALS		
DRAWN: ECJ	SCALE: N/A	SHEET: 1 OF 6
ENGINEER: GFM		SIZE: B



DWG NO.	REV:
WSMB-11456	A - 0



QTY	ITEM NUMBER/BIN	DESCRIPTION	MANUFACTURING PART NUMBER OR DRAWING NUMBER	REV LEVEL	COMMENTS
ENCLOSURE WITH INTERNALS					
10	1	BUSS BAR - GROUND RAIL	MULTIPURPOSE 110 COOPER BAR 1" X 36" X 3/16"	2557T583 McMASTER CARR	MUST BE MACHINED TO DWG# WSMB-11456-GND-BUSS
20	2	BUSS BAR - POWER RAIL	MULTIPURPOSE 110 COOPER BAR 1.5" X 12" X 3/16"	2557T591 McMASTER CARR	MUST BE MACHINED TO DWG# WSMB-11456-POS-BUSS
30	1	LABEL SET	ENCLOSURE LABEL SET	WSMB-11456-ENCL-LBL	
40	1	ENCLOSURE	STAINLESS STEEL 24" X 16" X 8"	SCE-24H1608SSLP	
50	1	ENCLOSURE INTERNAL PANEL	STAINLESS STEEL 24" X 16"	SCE-24P16	MUST BE MACHINED TO DWG# WSMB-11456-PLATE
60	6	0419003	REVERSING CONTRACTOR TROMBETTA 241.1231.A51	MURCAL INC TMT 214-1231-A51	
70	2	0419002	100 AMP AUTO RESET CIRCUIT BREAKER	BUS 181100F/WAYTEK WIRE 46935	
80	20	0419004	EYELET FOR 6GA WIRE 3/8"		
90	25		EYELET FOR 6GA WIRE 1/4"	7113k446 McMASTER CARR	
100	20	G1-20	SPADE CONNECTOR		
110	50		GENERAL PURPOSE WASHER	92916A395 McMASTER CARR	
120	50		THIN HEX NUT	92174A662 McMASTER CARR	
130	50		LOCK WASHER	93496A030 McMASTER CARR	
140	21	RIVET NUT	1/4"-20 THREAD HEAVY DUTY RIVET NUT	McMASTER CARR 95105A143	
OTHER ITEMS					
150	1	1.5" PANDUIT SHOP SUPPLY	1/4"-20 THREAD HEAVY DUTY RIVET NUT		
160	1	D8-07	6 POSITION TERMINAL STRIP		

CUSTOMER: HYBEKO AS

DESCRIPTION: ENCLOSURE BILL OF MATERIALS



DRAWN: ECJ
ENGINEER: GFM

SCALE: N/A

SHEET: 2 OF 6

SIZE: B

DWG NO.

WSMB-11456

REV:

A - 0

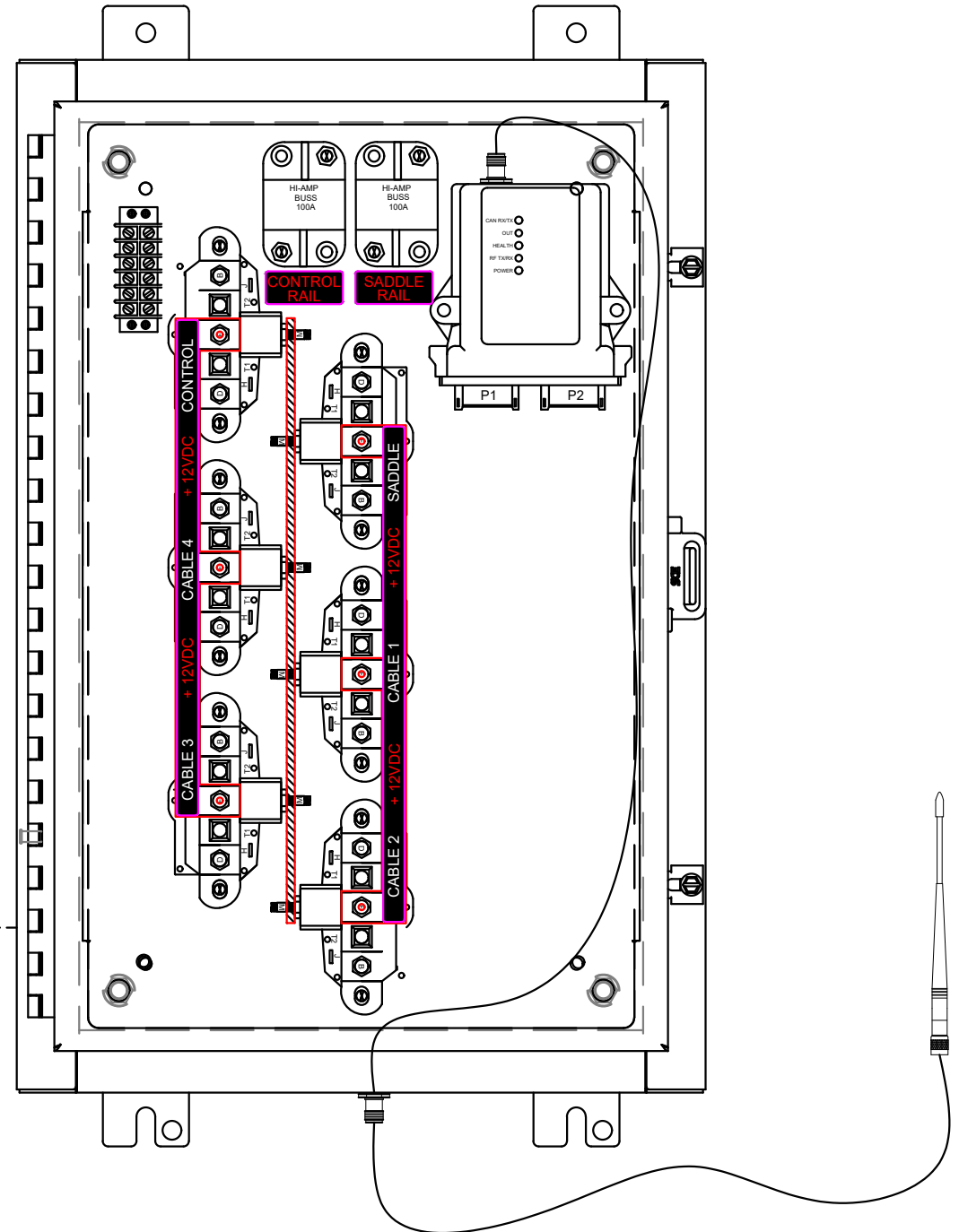
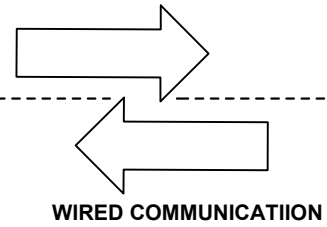
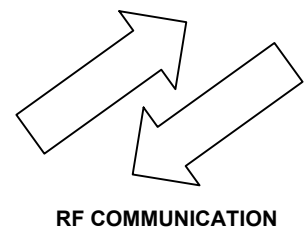
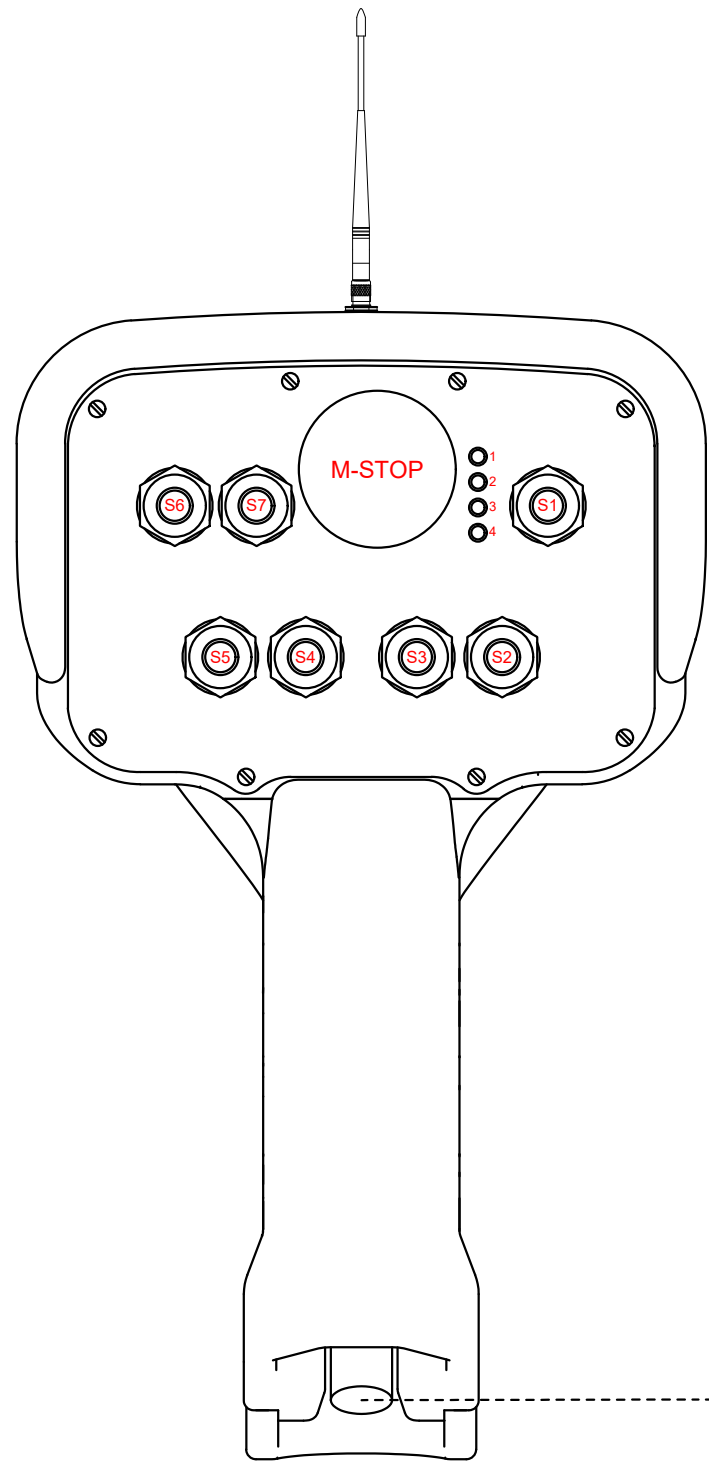

NOTES:

- 1) REFERENCE THE 5-DIGIT PROJECT-SPECIFIC WS# (SEE TITLE BLOCK BELOW) WHEN ORDERING INDIVIDUAL PARTS OR A COMPLETE SYSTEM.
- 2) APPLICATION SPECIFIC SPARE PARTS TO BE ORDERED USING PART NUMBERS REFERENCED ON SHEET 1 AND 2.
- 3) CONFIGURATION WITH BASE UNIT IS TO BE 1:1.
- 4) SYSTEM WILL UTILIZE DIRECT SEQUENCE SPREAD SPECTRUM FREQUENCY HOPPING TECHNOLOGY.
- 5) LINK LOSS CRITERIA: 1 SEC

RANGE TEST _____

CUSTOMER: HYBEKO AS			
DESCRIPTION: SYSTEM DIAGRAM			
DRAWN: ECJ	SCALE: N/A	SHEET: 3 OF 6	SIZE: B
ENGINEER: GFM		DWG NO. WSMB-11456	REV: A - 0

HANDHELD DETAILS		
INACTIVITY TIMEOUT	10 MINUTES	
ASSOCIATION	STANDARD DEFAULT	(S1+/S7+)
MIN/MAX ADJUSTMENT	N/A	
ASSOCIATION PROCEDURE	TRANSMITTER AND BASE UNIT MUST BE OFF.	
	1. M-STOP IN THE ON POSITION.	
	2. OPERATE SWITCHES S1+ AND S7+ AND HOLD.	
	3. ALL FOUR LED'S WILL TURN ON, CONTINUE TO HOLD SWITCHES.	
	4. ALL LED'S WILL TURN OFF AND "TX" LED WILL BEGIN TO BLINK.	
	5. TURN ON BASE UNIT.	
LOW VOLTAGE WARNING		
VOLTAGE SHUTDOWN		
UMBILICAL CHECK (IF APP)		
CHECK SUM:		
SOFTWARE:		
NOTES:		

- 9X - 900 MHz
- 2H - 2.4 GHz

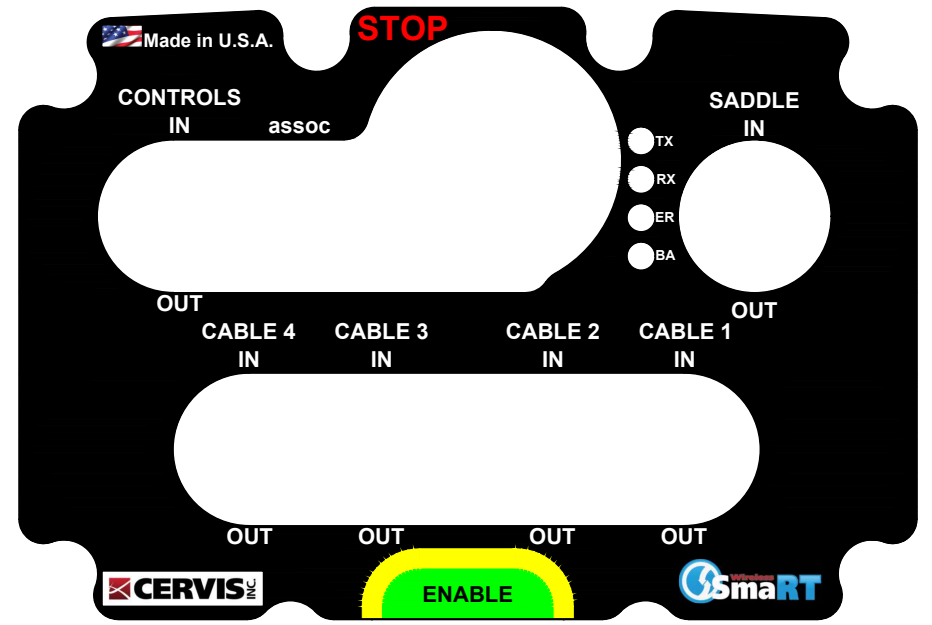
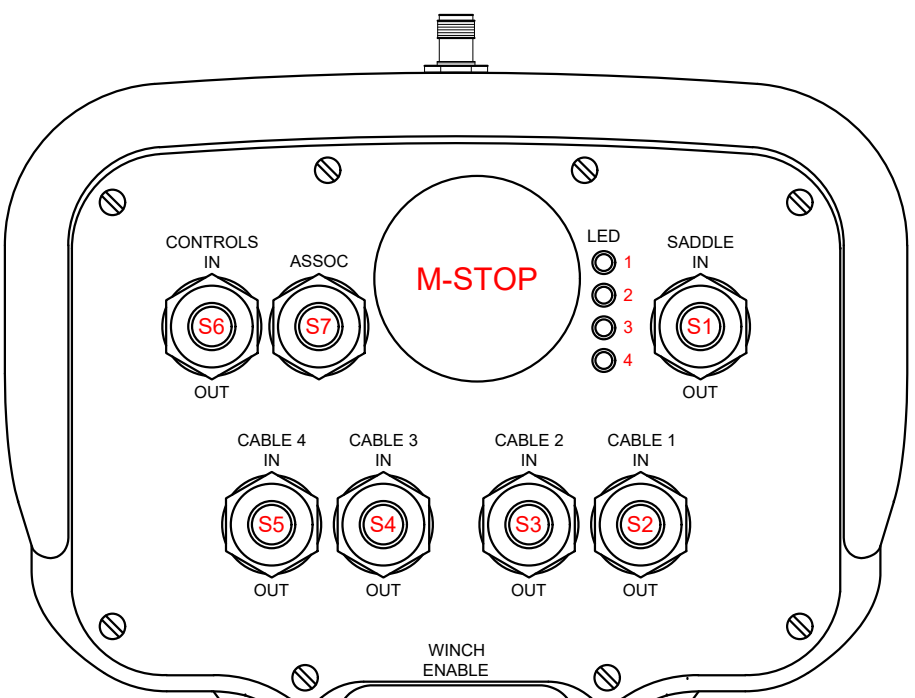

LED	STATUS	COLOR
LED 1	TX	GREEN
LED 2	RX	AMBER
LED 3	ERR	RED
LED 4	BAT	AMBER

SWITCH TYPE	START UP CONDITION
STOP	PUSH TO ACTIVATE/TWIST UP TO DEACTIVATE
S1	3 POSITION MOMENTARY TOGGLE SWITCH
S2	3 POSITION MOMENTARY TOGGLE SWITCH
S3	3 POSITION MOMENTARY TOGGLE SWITCH
S4	3 POSITION MOMENTARY TOGGLE SWITCH
S5	3 POSITION MOMENTARY TOGGLE SWITCH
S6	3 POSITION MOMENTARY TOGGLE SWITCH
S7	3 POSITION MOMENTARY TOGGLE SWITCH
TRIGGER	SPRING RELEASE TRIGGER

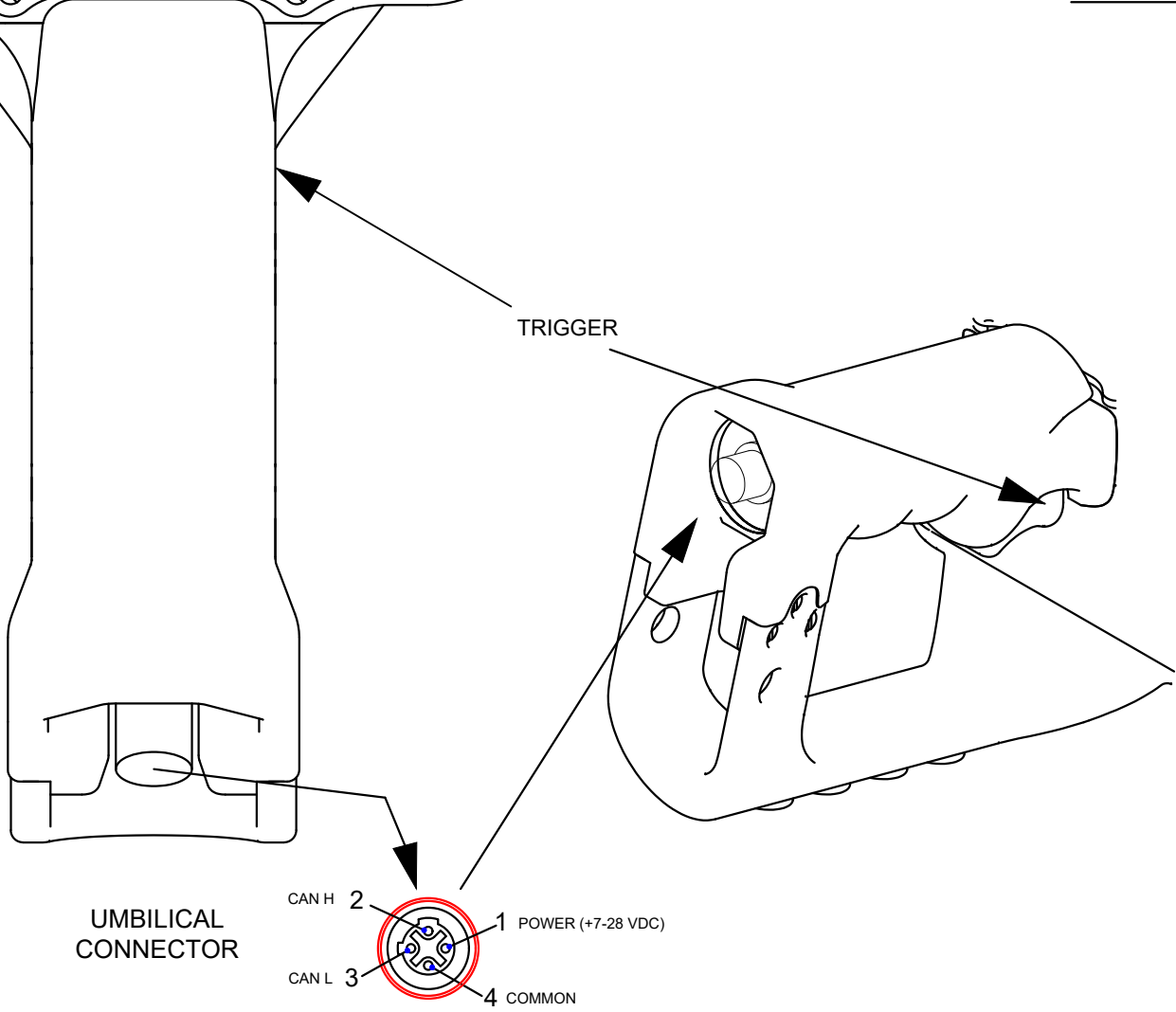

CUSTOMER: HYBEKO AS					
DESCRIPTION: HANDHELD CONFIGURATION					
DRAWN: ECJ	SCALE: N/A	SHEET: 4 OF 6	SIZE: B	DWG NO. WSMB-11456	REV: A - 0
ENGINEER: GFM					

REQUIRED FIELDS	DESCRIPTION	DETAILS
CONTROL POWER	7-32 VDC	12VDC
ANTENNA OPTION	EXTERNAL	
CAN CONFIGURATION		
CAN TERMINATION	1.0kΩ (Standard default)	
CHECK SUM:		
SOFTWARE:		

BASE UNIT SAFETY LINK	
WHEN ANY OF THE FOLLOWING OCCURS:	
<ul style="list-style-type: none"> MACHINE STOP IS PRESSED HANDHELD UNIT GOES OUT OF RANGE HANDHELD UNIT DEACTIVATES DUE TO LOSS OF POWER, INACTIVITY TIMEOUT, OR DELIBERATE DEACTIVATION (OFF SWITCH) 	
X	
ENABLED	DISABLED
ALL LATCHED OUTPUTS UNLATCH AND ALL MOMENTARY OUTPUTS THAT ARE ACTIVE DEACTIVATE. UPON ACTIVATION OF THE HANDHELD, NO OUTPUTS ARE ALLOWED TO BE ACTIVATED UNTIL ALL SWITCHES (UNLESS MASKED) ARE FIRST CENTERED OR RETURNED TO THEIR NEUTRAL STATE.	ALL LATCHED OUTPUTS REMAIN LATCHED, BUT ALL MOMENTARY COMMANDS THAT ARE ACTIVE DEACTIVATE.
NOTE: IF HANDHELD UNIT IS POWERED ON AND A MOMENTARY COMMAND THAT WAS DEACTIVATED DUE TO RANGE IS STILL ACTIVE WHEN THE HANDHELD RETURNS IN RANGE THE OUTPUT WILL IMMEDIATELY BE ACTIVE AGAIN.	

		BASE UNIT SOFTWARE CONFIGURATION															
		OUTPUT CHANNEL															
		K1	K2	K3	K4	K5	K6	K7	K8	K9	K10	K11	K12	K13	K14	K15	K16
TRANSMITTER ACTIVATION	S1+ + TRIGGER AND NOT S2,S3,S4,S5,S6	M															
	S1- + TRIGGER AND NOT S2,S3,S4,S5,S6		M														
	S2+ + TRIGGER			M													
	S2- + TRIGGER				M												
	S3+ + TRIGGER					M											
	S3- + TRIGGER						M										
	S4+ + TRIGGER							M									
S4- + TRIGGER								M									
S5+ + TRIGGER									M								
S5- + TRIGGER										M							
S6+ + TRIGGER AND NOT S1,S2,S3,S4,S5											M						
S6- + TRIGGER AND NOT S1,S2,S3,S4,S5												M					
LINK																	M

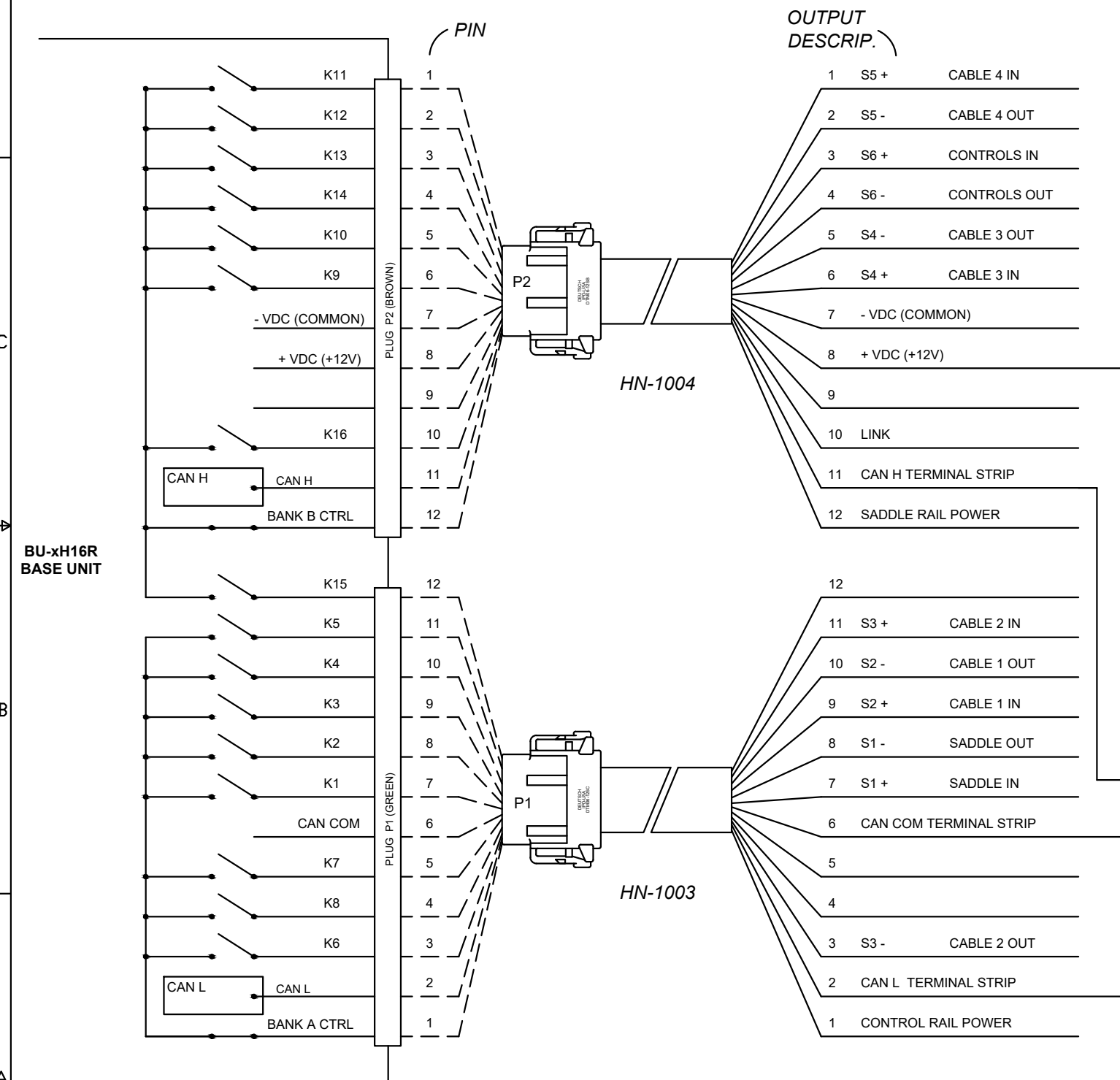

BASE UNIT LEDs	
CAN RX/TX	CAN Receive/Transmit
OUT	Output active
HEALTH	Health ok
RF TX/RX	RF Transmit/Receive
POWER	Power ok/fault

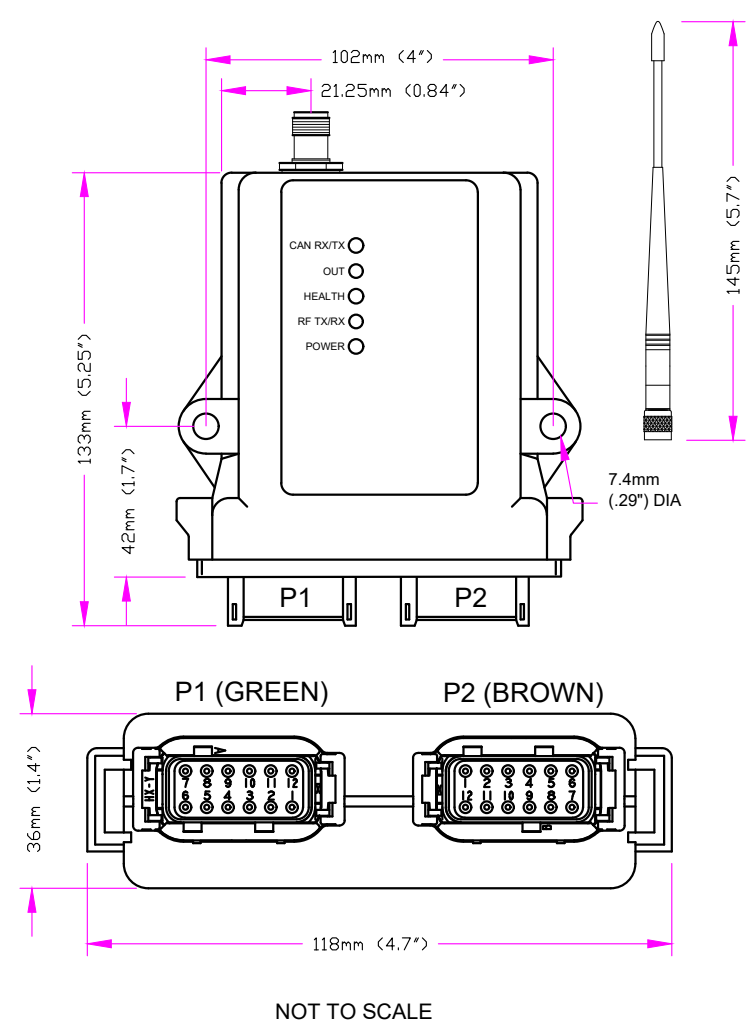

CUSTOMER: HYBEKO AS		DESCRIPTION: BASE UNIT CONFIGURATION		DRAWN: ECJ		SCALE: N/A		SHEET: 5 OF 6		SIZE: B		DWG NO. WSMB-11456		REV: A - 0	
ENGINEER: GFM															



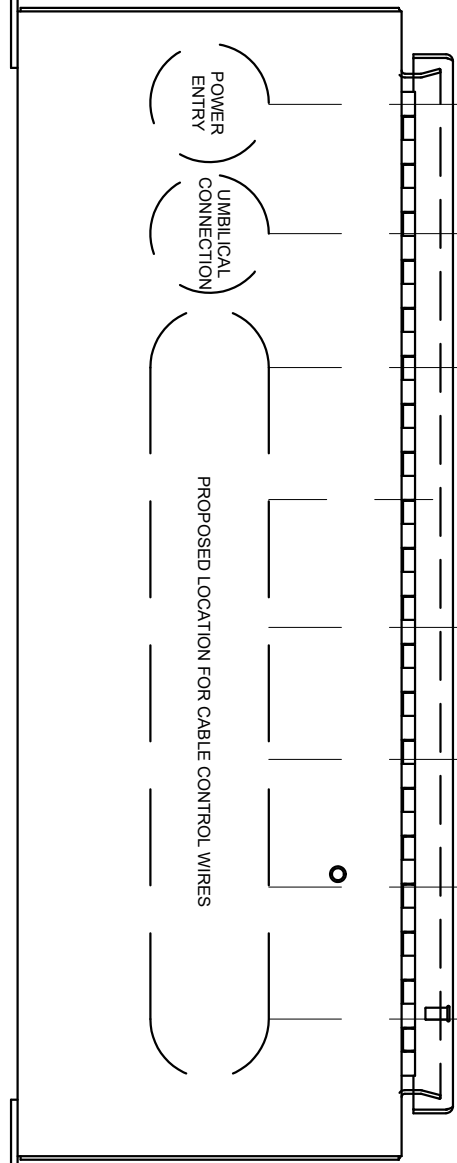

LEFT SIDE VIEW

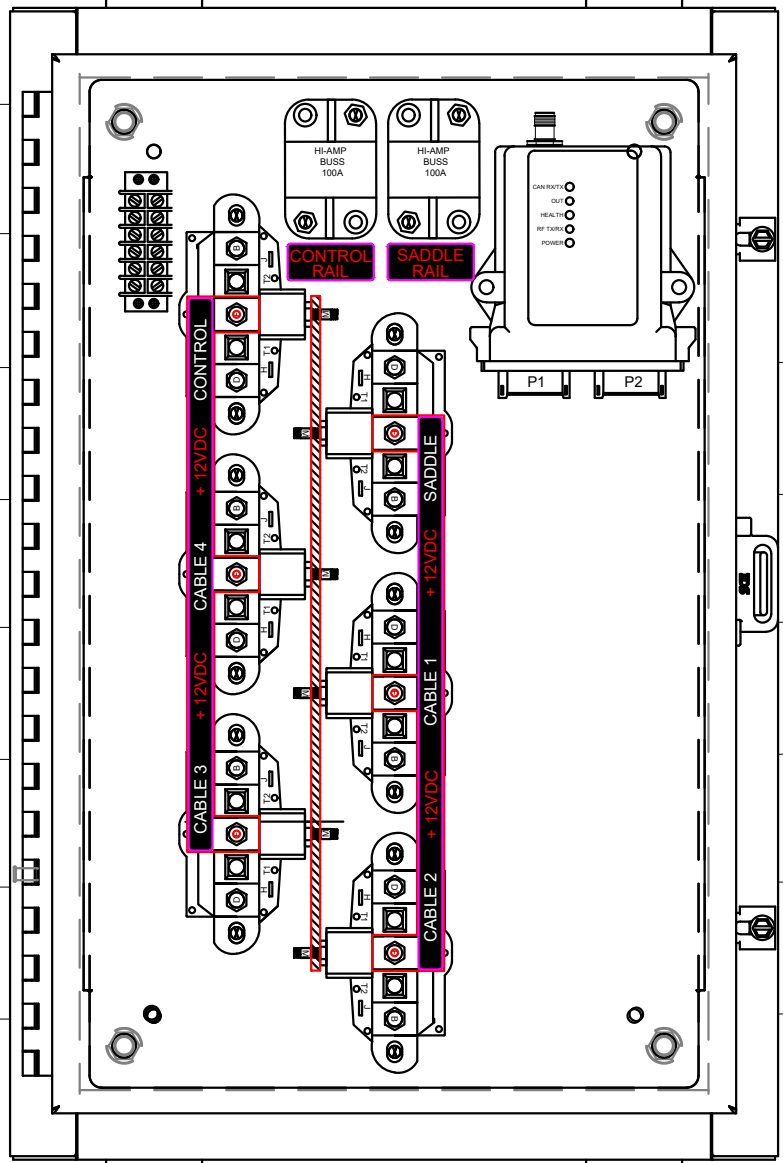

FRONT VIEW

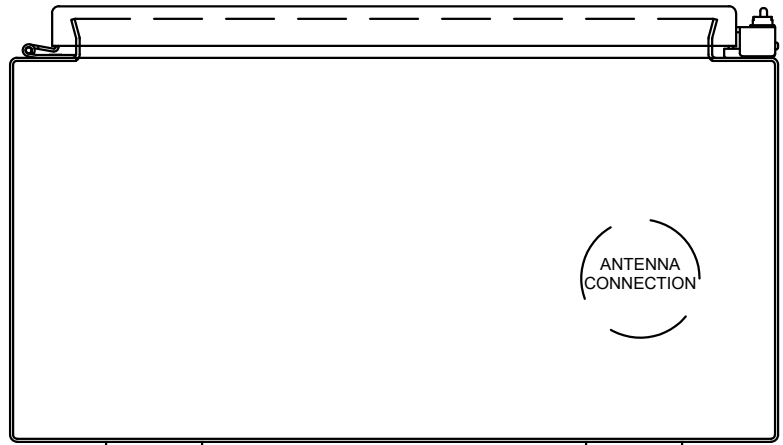

BOTTOM VIEW

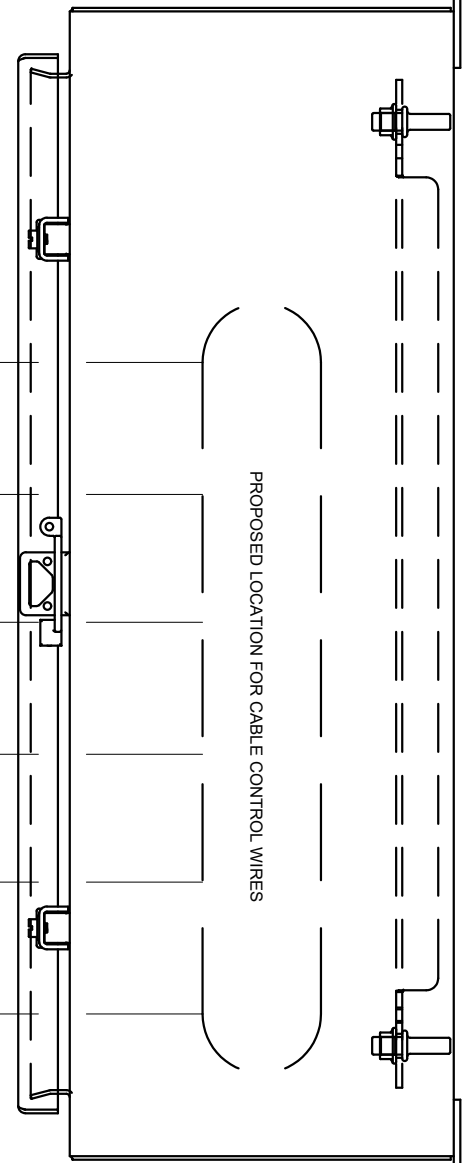

RIGHT SIDE VIEW

CUSTOMER: HYBEKO AS			
DESCRIPTION: ENCLOSURE LAYOUT			
DRAWN: ECJ	SCALE: N/A	SHEET: 6 OF 6	SIZE: B
ENGINEER: GFM			DWG NO. WSMB-11456

Fuse Overview

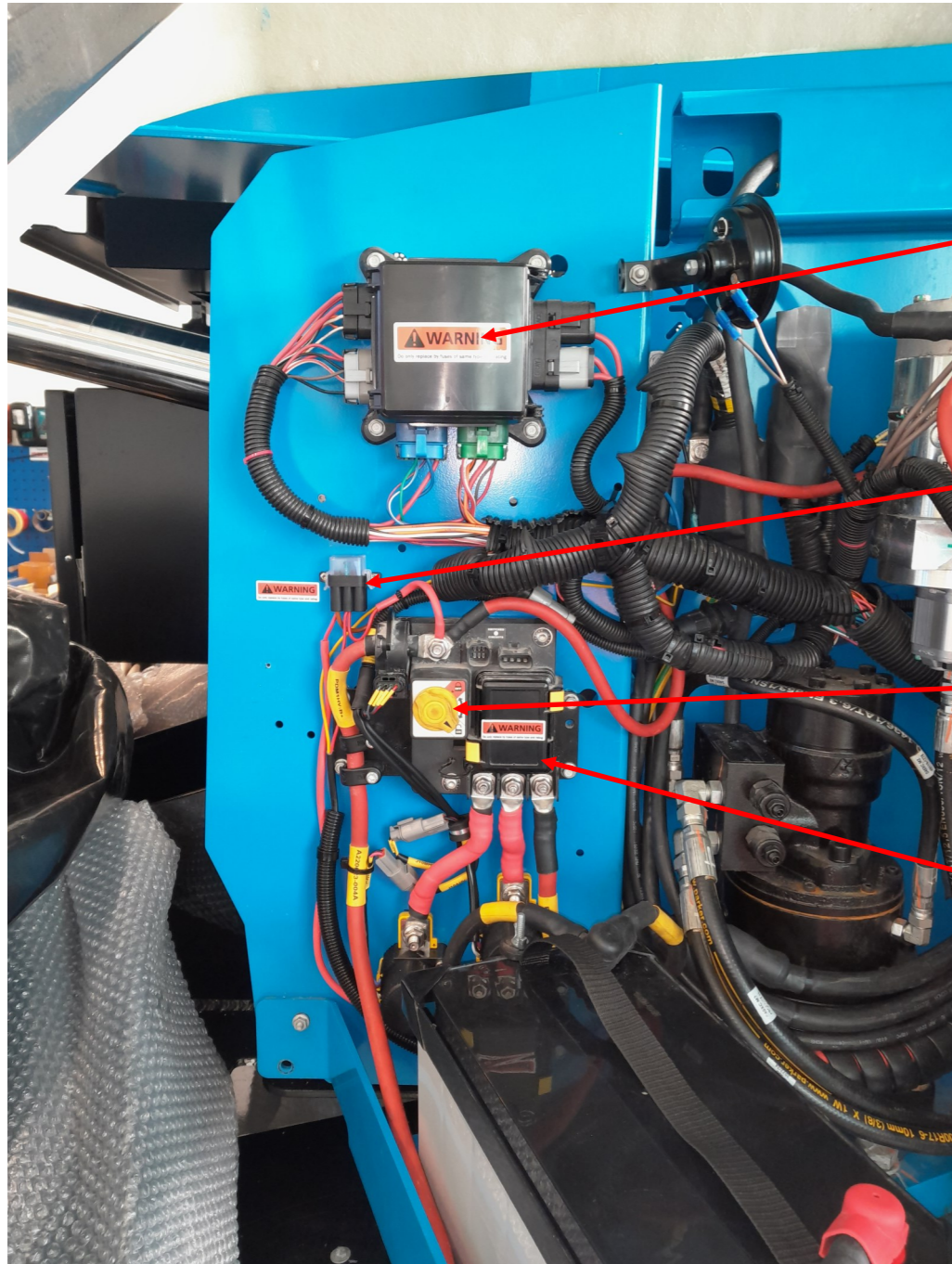

Engine Fuse box

Ext fuse box
F1 Dist warning system 15A
F2 Mascot 12V charger 15A

Main Switch

PDM1HV
DC-DC Converter 200A
K2 Vinch 2 100A
K1 Vinch 1 100A

MSD (Manual service disconnect)
Disconnect high-voltage battery
from system

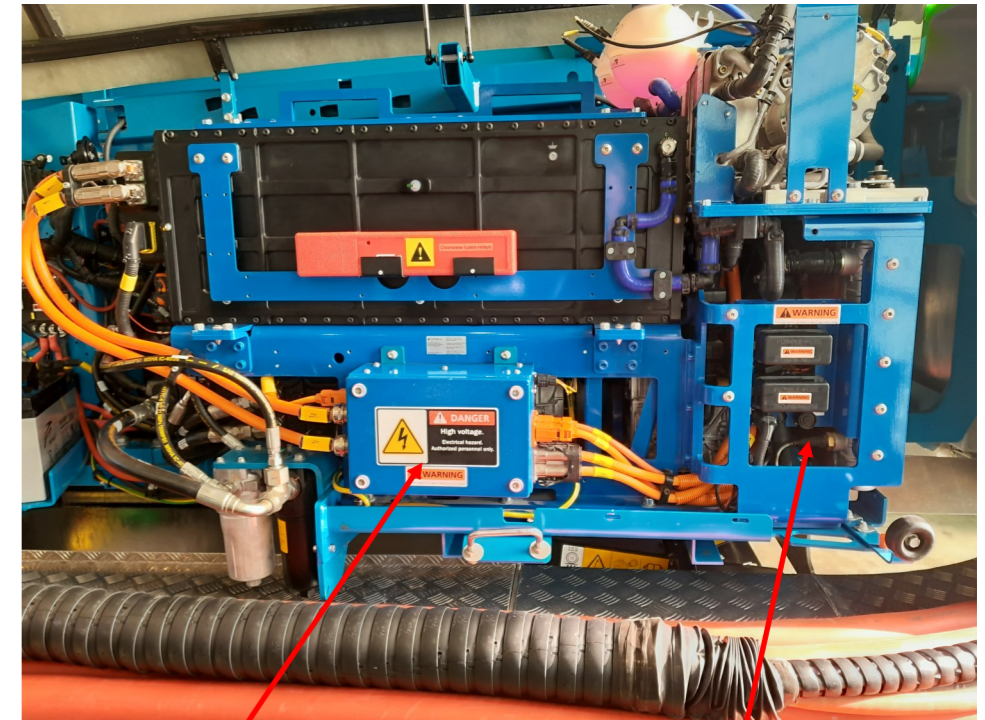

PDU (Power distribution unit)

PDM2 (power distribution module 2)

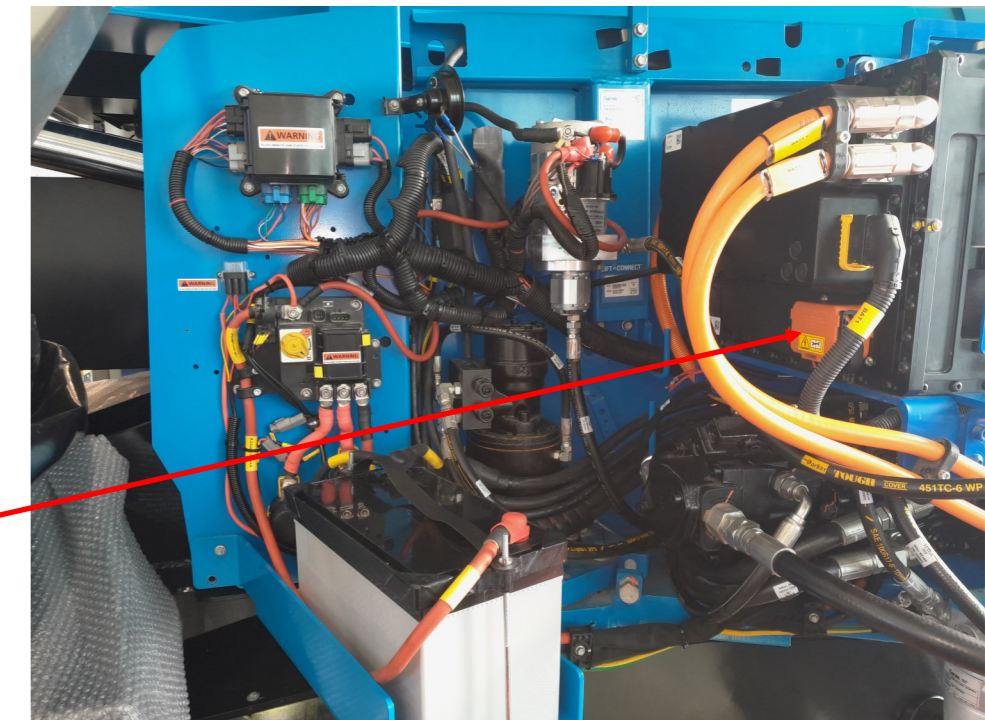

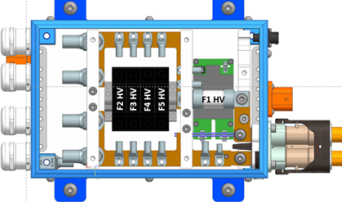
PDU	FUSE No.	FUNCTION	RATING
	F1HV	Inverter	250A
	F2HV	Charger	25A
	F3HV	HV compressor	25A
	F4HV	Battery heater	25A

PDM1HV	FUSE No.	FUNCTION	RATING
	F7HV	Winch	200A
	F8HV	Winch	200A
	F9HV	INV - DC/DC CONVERTER OUTPUT	200A

PDM2HV	FUSE No.	FUNCTION	RATING																																
<table border="1" data-bbox="139 661 698 876"> <tr><td>N/A</td><td>N/A</td><td>N/A</td><td>N/A</td><td>N/A</td><td>N/A</td></tr> <tr><td colspan="2">CR1HV</td><td colspan="2">N/A</td><td colspan="2">N/A</td></tr> </table> <table border="1" data-bbox="349 923 497 977"> <tr><td>F10HV – 30A</td></tr> </table> <table border="1" data-bbox="139 1012 698 1229"> <tr><td>F13HV 5A</td><td>F14HV 5A</td><td>F15HV 5A</td><td>F16HV 5A</td><td>F17HV 10A</td><td>F18HV 10A</td></tr> <tr><td>CR2HV</td><td>CR3HV</td><td>CR4HV</td><td>CR5HV</td><td>CR6HV</td><td>CR7HV</td></tr> <tr><td>F12HV 5A</td><td rowspan="2">CR8HV</td><td rowspan="2">CR9HV</td><td rowspan="2">CR10HV</td><td rowspan="2">CR11HV</td><td rowspan="2">CR12HV</td></tr> <tr><td>F11HV 10A</td></tr> </table>	N/A	N/A	N/A	N/A	N/A	N/A	CR1HV		N/A		N/A		F10HV – 30A	F13HV 5A	F14HV 5A	F15HV 5A	F16HV 5A	F17HV 10A	F18HV 10A	CR2HV	CR3HV	CR4HV	CR5HV	CR6HV	CR7HV	F12HV 5A	CR8HV	CR9HV	CR10HV	CR11HV	CR12HV	F11HV 10A	F10HV	CF – Cooling fan	30A
	N/A	N/A	N/A	N/A	N/A	N/A																													
	CR1HV		N/A		N/A																														
	F10HV – 30A																																		
	F13HV 5A	F14HV 5A	F15HV 5A	F16HV 5A	F17HV 10A	F18HV 10A																													
	CR2HV	CR3HV	CR4HV	CR5HV	CR6HV	CR7HV																													
	F12HV 5A	CR8HV	CR9HV	CR10HV	CR11HV	CR12HV																													
	F11HV 10A																																		
	F11HV	HEC – Electrification control unit	10A																																
	F12HV	Logic, diagnostics	5A																																
	F13HV	KL30HV: HV Battery logic, PDU, Charge wake-up	5A																																
	F14HV	KL30HV: Inverter, HMI	5A																																
	F15HV	KL30HV: Compressor, heater	5A																																
	F16HV	HV Battery contactors	5A																																
	F17HV	BCP – Battery coolant pump	10A																																
	F18HV	CCP – Components coolant pump	10A																																
		RELAY No.	FUNCTION	RELAY TYPE																															
	CR1HV	CF – Cooling fan	ISO 7588-1 Mini relay																																
CR2HV	KL30HV: HV Battery logic, PDU, Charge wake-up	ISO 280 Ultra Micro																																	
CR3HV	KL30HV: Inverter, HMI	ISO 280 Ultra Micro																																	
CR4HV	KL30HV: Compressor, heater	ISO 280 Ultra Micro																																	
CR5HV	HV Battery contactors	ISO 280 Ultra Micro																																	
CR6HV	BCP – Battery coolant pump	ISO 280 Ultra Micro																																	
CR7HV	CCP – Components coolant pump	ISO 280 Ultra Micro																																	
CR8HV	INV/Motor HVIL circuit	ISO 280 Ultra Micro																																	
CR9HV	FW Drive enable	ISO 280 Ultra Micro																																	
CR10HV	REV Drive enable	ISO 280 Ultra Micro																																	
CR11HV	Brakes enable	ISO 280 Ultra Micro																																	
CR12HV	SW inhibit	ISO 280 Ultra Micro																																	

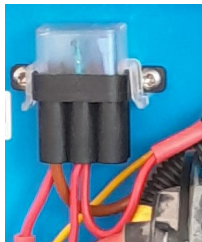

Ext. fusebox	Function	Rating
F1	Distance warning	15A
F2	Ext. Charger 110V to 12V	15A

Engine Relay Layout

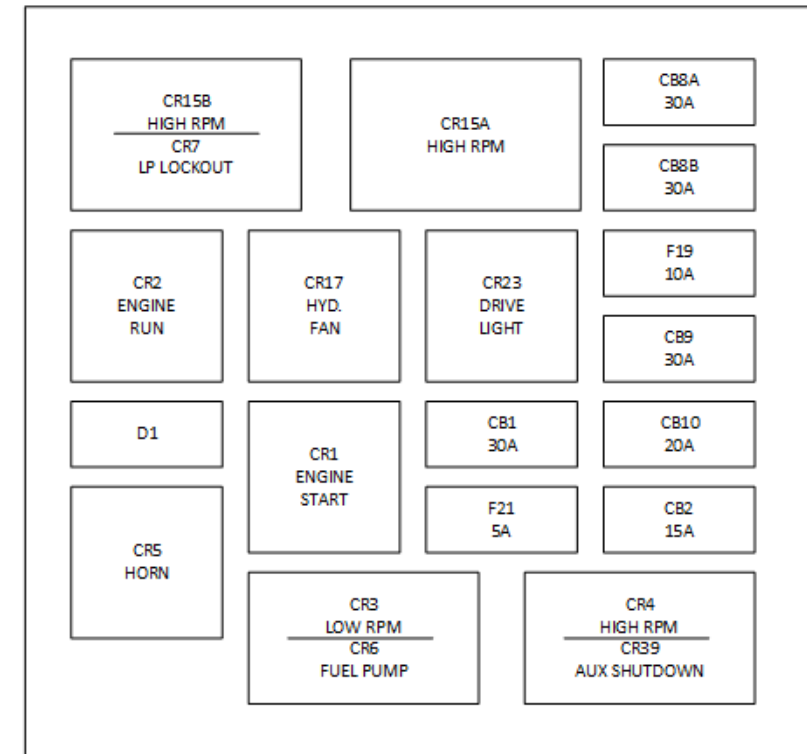

Fuses	Rating	Function
F19	10A	Drive Light
F21	5A	Telematic option
CB1	30A	Engine control power
CB2	15A	System control logic power
CB8A	30A	Glow plug 1
CB8B	30A	Glow plug 2
CB9	30A	Engine run / option / acc
CB10	20A	System control driver power
Diode		
D1	6A	Alternator Exc
Relays		
CR1		Engine start
CR2		Engine run
CR3/CR6		Low rpm / Fuel pump
CR4/CR39		High RPM </ Fuel pump
CR5		Horn
CR15A		Engine glow plug A
CR15B / CR7		Engine glow plug B / LPG Solenoid
CR17		Hydraulic oil cooler (option)
CR23		Drivelight
CR39		Aux shut down



HYBRiA PROPRIETARY, CONFIDENTIAL AN/OR TRADE SECRET

Do not Use, Reproduce, Publish or Disclose to Others Without Express Authorization By Hybria Ltd, Finland.

TITLE
Hybeko S-45XC Electric – FUSES, RELAYS AND NOTES

MODEL
HYBEKO S-45XC ELECTRIC

DRAWING NO
D20221106-001A

PAGE
1

CREATED BY / DATE
MHE 26.04.2023

REVISED BY / DATE

REVISION DESCRIPTION
Document created

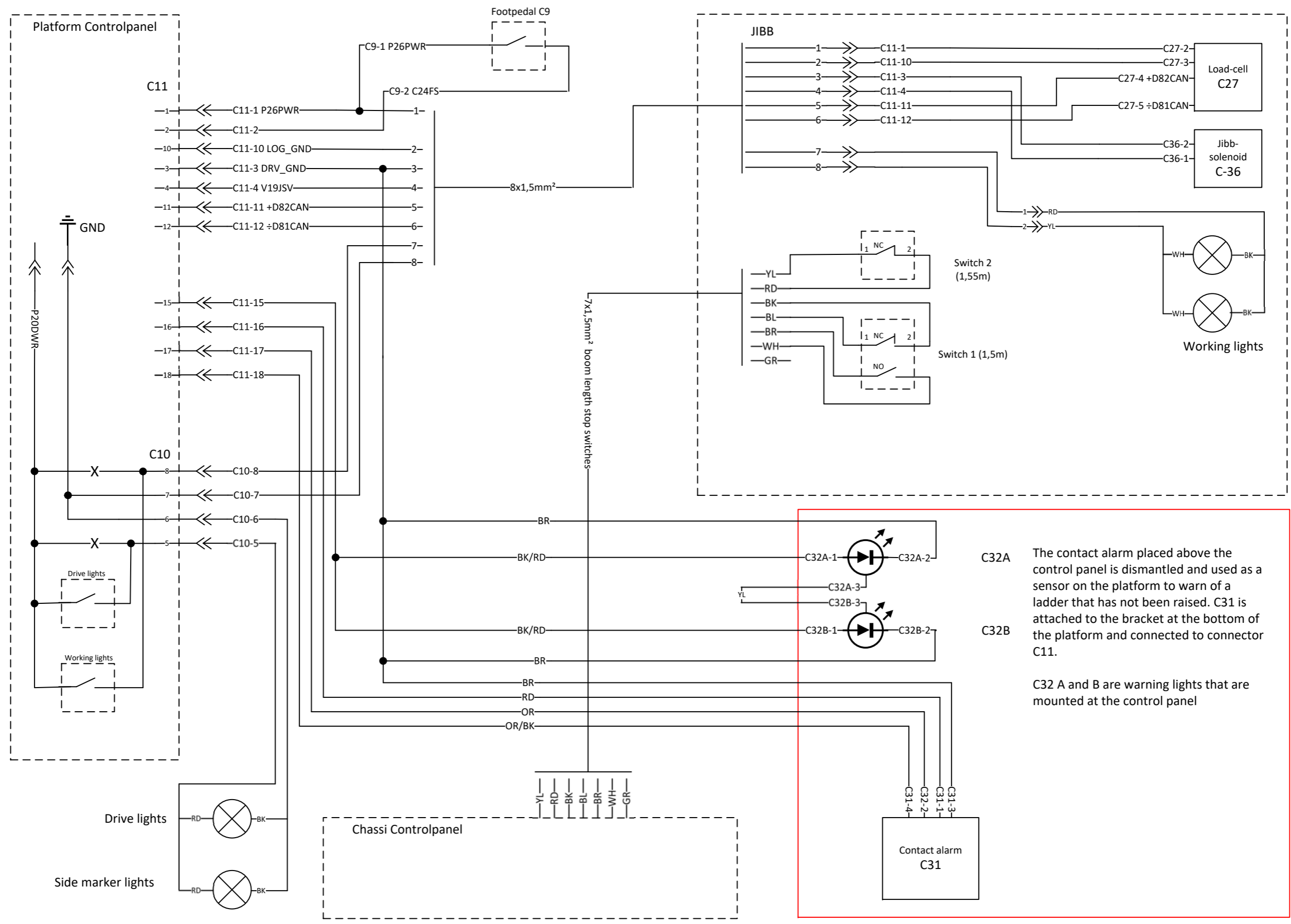

C32A The contact alarm placed above the control panel is dismantled and used as a sensor on the platform to warn of a ladder that has not been raised. C31 is attached to the bracket at the bottom of the platform and connected to connector C11.

C32B C31 is attached to the bracket at the bottom of the platform and connected to connector C11.

C32 A and B are warning lights that are mounted at the control panel

BL	Blue	WH	White	GR/BK	Green / Black	WH/BK	White / Black
BK	Black	YL	Yellow	GR/WH	Green 7 White	WH/RD	White / Red
BR	Brown	BL/BK	Blue / Black	OR/BK	Orange / Black	WH/YL	White / Yellow
GR	Green	BL/RD	Blue / Red	OR/RD	Orange / Red	YL/BK	Yellow / Black
OR	Orange	BL/WH	Blue / White	OR/WH	Orange / White		
PP	Purple	BK/RD	Blue / Red	RD/BK	Red / Black		
RD	Red	BK/WH	Black / White	RD/WH	Red / White		



Project		Page
Hybeko Shore Power Machine		1 - 2
Drawing		Drawing no
Hybeko S-45XC Jibb-turtable		HSPM-S45XC-EL01
Created by / Date	Rev.	Rev. date
KHO / 09.11.2023	1	

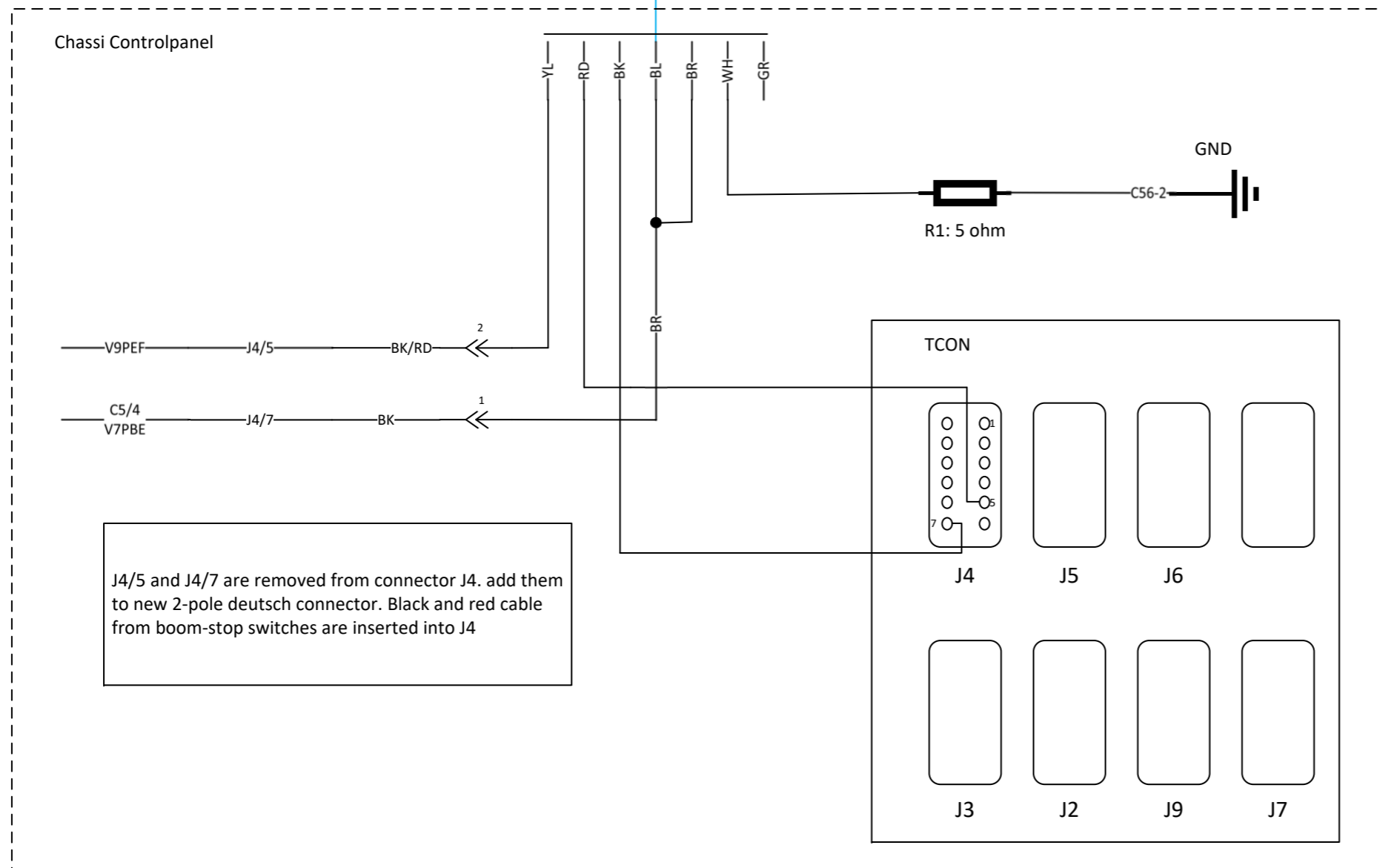

HYBEKO

Project	Hybeko Shore Power Machine	Page	2 - 2
Drawing	Hybeko S-45XC Jibb-turntable	Drawing no	HSPM-S45XC-EL01
Created by / Date	KHO / 09.11.2023	Rev.	1
		Rev. date	

Electrical Schematic, Turntable Controller

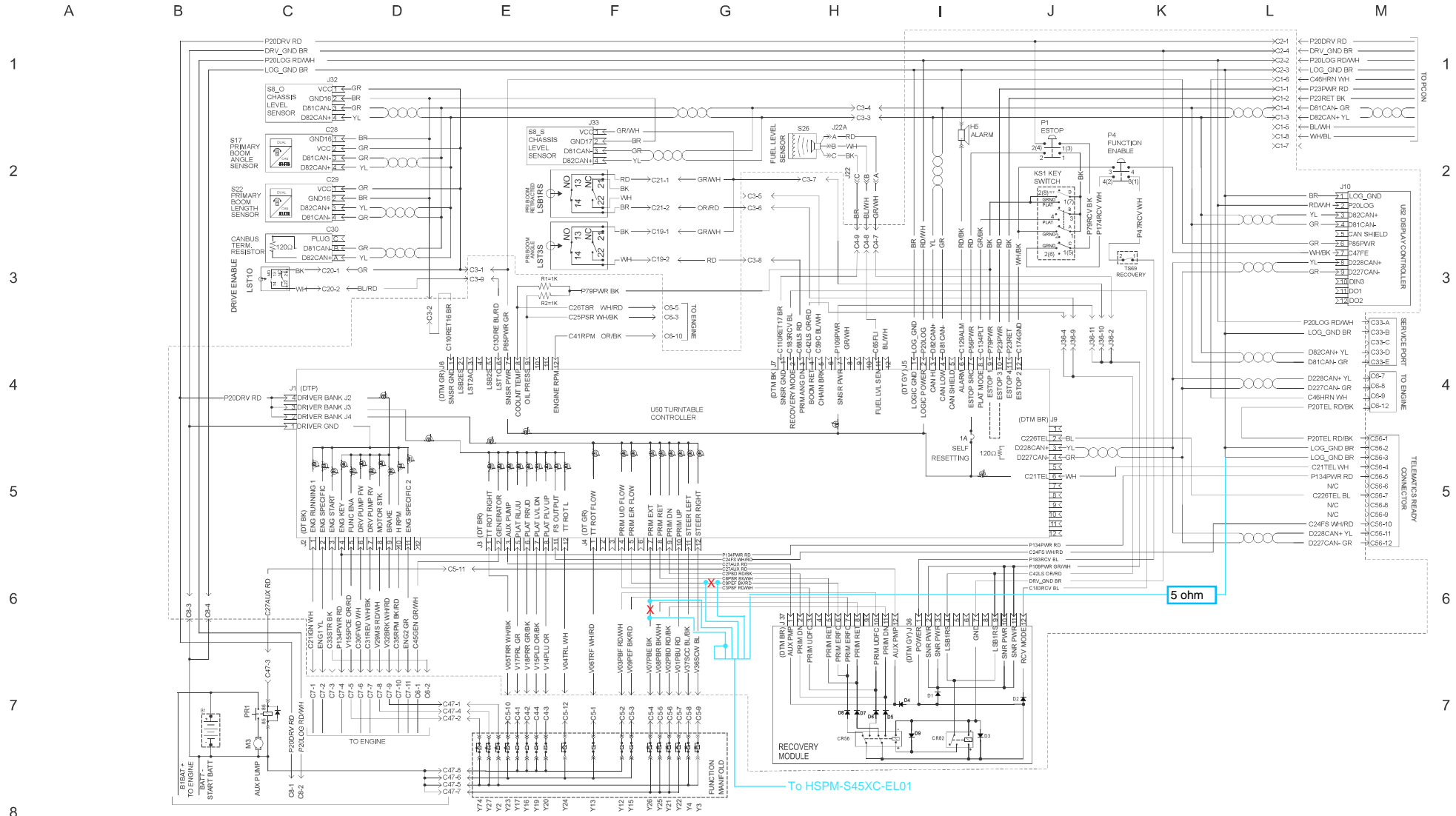

Project: Hybeko Shore Power Machine	
Drawing: Boom ext stop 1.5m	El-Skjema nr: HSPM-S45XC-EL-03
Drawing: Kjell Hegge-Olsen	
Date: 09.11.2023	



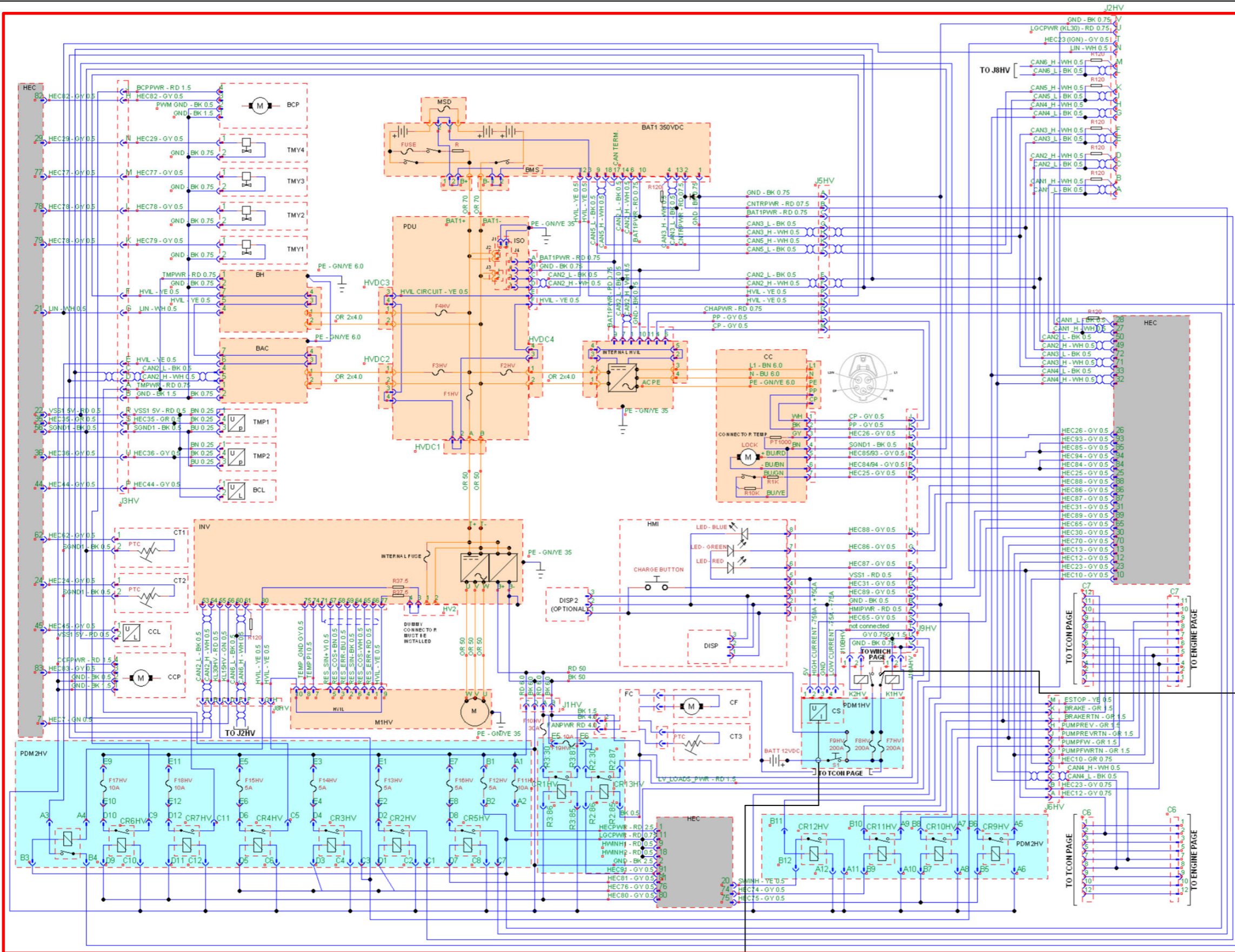

F1 15A To distanse warning page

110VAC

Mascot 2440 charger

GND



Project		Page
Hybeko Shore Power Machine		1
Drawing		Drawing no
Hybeko S-45XC Ext. components		HSPM-S45XC-EL04
Created by / Date	Rev.	Rev. date
KHO / 08.03.2024	1	